

SYLVANIA **SERVICE MANUAL**

**13" COLOR
TELEVISION
C6413TD**

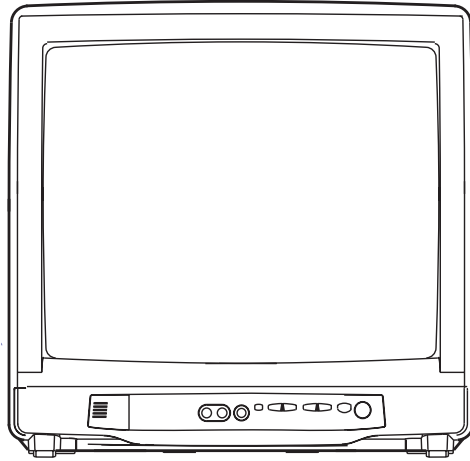

**19" COLOR
TELEVISION
C6419TD**

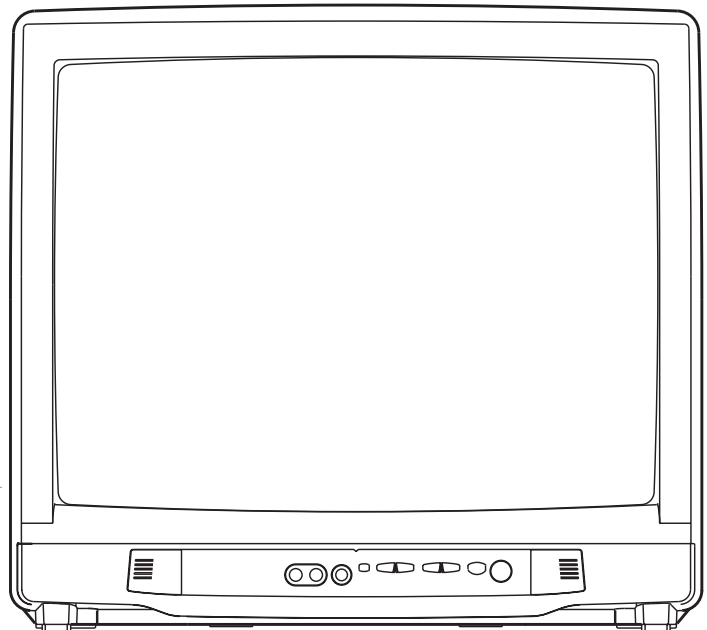

IMPORTANT SAFETY NOTICE

Proper service and repair is important to the safe, reliable operation of all Funai Equipment. The service procedures recommended by Funai and described in this service manual are effective methods of performing service operations. Some of these service special tools should be used when and as recommended.

It is important to note that this service manual contains various CAUTIONS and NOTICES which should be carefully read in order to minimize the risk of personal injury to service personnel. The possibility exists that improper service methods may damage the equipment. It also is important to understand that these CAUTIONS and NOTICES ARE NOT EXHAUSTIVE. Funai could not possibly know, evaluate and advise the service trade of all conceivable ways in which service might be done or of the possible hazardous consequences of each way. Consequently, Funai has not undertaken any such broad evaluation. Accordingly, a servicer who uses a service procedure or tool which is not recommended by Funai must first use all precautions thoroughly so that neither his safety nor the safe operation of the equipment will be jeopardized by the service method selected.

TABLE OF CONTENTS

Specifications	1-1	CBA Views and Test Points.....	7-9
Important Safety Precautions.....	2-1	Wave Forms	8-1
Standard Notes for Servicing	3-1	Wiring Diagram.....	9-1
Disassembly Instructions	4-1	IC Pin Function	10-1
Electrical Adjustment Instructions	5-1	Cabinet Exploded View	11-1
Block Diagram.....	6-1	Packing Exploded View	11-5
Schematic Diagram / CBA's and Test Points	7-1	Mechanical Parts List	12-1
Schematic Diagram	7-3	Electrical Parts List.....	13-1

SPECIFICATIONS

<TUNER>

ANT. Input ----- 75ohm Unbal., F type
 Reference Level-----20Vp-p (CRT Green Cathode)
 Test Input Signal -----400Hz 30% modulation

Description	Condition	Unit	Nominal	Limit
1. Intermediate Freq.	Picture	MHz	45.75	-
	Sound	MHz	41.25	-
2. Peak Picture Sens	VHF	dB μ v	15	30
	CATV	dB μ v	15	30
	UHF	dB μ v	15	40
3. AFT Pull In Range (10mV input)	-	MHz	\pm 2.0	\pm 0.7

<DEFLECTION>

[C6413TD]

Description	Condition	Unit	Nominal	Limit
1. Deflection Freq.	Horizontal	KHz	15.734	-
	Vertical	Hz	60	-
2. Linearity	Horizontal	%	-	\pm 15
	Vertical	%	-	\pm 10
3. Over Scan	-	%	10	-
4. High Voltage	-	KV	23	-

[C6419TD]

Description	Condition	Unit	Nominal	Limit
1. Deflection Freq.	Horizontal	KHz	15.734	-
	Vertical	Hz	60	-
2. Linearity	Horizontal	%	-	\pm 15
	Vertical	%	-	\pm 10
3. Over Scan	-	%	10	-
4. High Voltage	-	KV	26	-

<VIDEO & CHROMA>

[C6413TD]

Description	Condition	Unit	Nominal	Limit
1. Misconvergence	Center	mm	-	0.3
	Side	mm	-	1.2
	Corner	mm	-	1.5
2. Brightness	APL 100%	Ft-L	60	40
3. Color Temperature	-	°K	9200°K	-
4. Resolution	Horizontal	Line	250	-
	Vertical	Line	300	-

[C6419TD]

Description	Condition	Unit	Nominal	Limit
1. Misconvergence	Center	mm	-	0.4
	Side	mm	-	1.5
	Corner	mm	-	2.1
2. Brightness	APL 100%	Ft-L	40	25
3. Color Temperature	-	°K	9200°K	-
4. Resolution	Horizontal	Line	250	-
	Vertical	Line	300	-

<AUDIO>

All items are measured across 8Ω load at speaker output terminal.

Description	Condition	Unit	Nominal	Limit
1. Audio Output Power	10% THD	W	1	0.8
2. Audio Distortion (w/LPF)	500mW	%	2	7
3. Audio Freq. Response	-3dB	Hz	100~11K	-

Note:

Nominal specifications represent the design specifications. All units should be able to approximate these. Some will exceed and some may drop slightly below these specifications. Limit specifications represent the absolute worst condition that still might be considered acceptable. In no case should a unit fail to meet limit specifications.

IMPORTANT SAFETY PRECAUTIONS

Prior to shipment from the factory, our products are strictly inspected for recognized product safety and electrical codes of the countries in which they are to be sold. However, in order to maintain such compliance, it is equally important to implement the following precautions when a set is being serviced.

Safety Precautions for TV Circuit

1. **Before returning an instrument to the customer**, always make a safety check of the entire instrument, including, but not limited to, the following items:

- a. Be sure that no built-in protective devices are defective and have been defeated during servicing.
(1) Protective shields are provided on this chassis to protect both the technician and the customer. Correctly replace all missing protective shields, including any removed for servicing convenience.
(2) When reinstalling the chassis and/or other assembly in the cabinet, be sure to put back in place all protective devices, including but not limited to, nonmetallic control knobs, insulating fishpapers, adjustment and compartment covers/shields, and isolation resistor/capacitor networks. **Do not operate this instrument or permit it to be operated without all protective devices correctly installed and functioning. Servicers who defeat safety features or fail to perform safety checks may be liable for any resulting damage.**
- b. Be sure that there are no cabinet openings through which an adult or child might be able to insert their fingers and contact a hazardous voltage. Such openings include, but are not limited to, (1) spacing between the picture tube and the cabinet mask, (2) excessively wide cabinet ventilation slots, and (3) an improperly fitted and/or incorrectly secured cabinet back cover.
- c. **Antenna Cold Check** - With the instrument AC plug removed from any AC source, connect an electrical jumper across the two AC plug prongs. Place the instrument AC switch in the on position. Connect one lead of an ohmmeter to the AC plug prongs tied together and touch the other ohmmeter lead in turn to each tuner antenna input exposed terminal screw and, if applicable, to the coaxial connector. If the measured resistance is less than 1.0 megohm or greater than 5.2 megohm, an abnormality exists that must be corrected before the instrument is returned to the customer. Repeat this test with the instrument AC switch in the off position.
- d. **Leakage Current Hot Check** - With the instrument completely reassembled, plug the AC line cord directly into a 120V AC outlet. (Do not use an isolation transformer during this test.) Use a leak-

age current tester or a metering system that complies with American National Standards Institute (ANSI) C101.1 Leakage Current for Appliances and Underwriters Laboratories (UL) 1410, (50.7). With the instrument AC switch first in the on position and then in the off position, measure from a known earth ground (metal water pipe, conduit, etc.) to all exposed metal parts of the instrument (antennas, handle brackets, metal cabinet, screw heads, metallic overlays, control shafts, etc.), especially any exposed metal parts that offer an electrical return path to the chassis. Any current measured must not exceed 0.5 milli-ampere. Reverse the instrument power cord plug in the outlet and repeat the test.

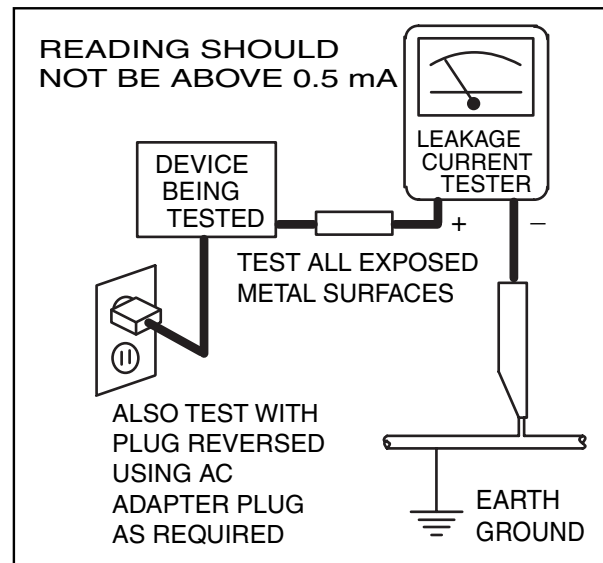

ANY MEASUREMENTS NOT WITHIN THE LIMITS SPECIFIED HEREIN INDICATE A POTENTIAL SHOCK HAZARD THAT MUST BE ELIMINATED BEFORE RETURNING THE INSTRUMENT TO THE CUSTOMER OR BEFORE CONNECTING THE ANTENNA OR ACCESSORIES.

- e. **X-Radiation and High Voltage Limits** - Because the picture tube is the primary potential source of X-radiation in solid-state TV receivers, it is specially constructed to prohibit X-radiation emissions. For continued X-radiation protection, the replacement picture tube must be the same type as the original. Also, because the picture tube shields and mounting hardware perform an X-radiation protection function, they must be correctly in place. High voltage must be measured each time servic-

ing is performed that involves B+, horizontal deflection or high voltage. Correct operation of the X-radiation protection circuits also must be reconfirmed each time they are serviced. (X-radiation protection circuits also may be called "horizontal disable" or "hold down.") Read and apply the high voltage limits and, if the chassis is so equipped, the X-radiation protection circuit specifications given on instrument labels and in the Product Safety & X-Radiation Warning note on the service data chassis schematic. High voltage is maintained within specified limits by close tolerance safety-related components/adjustments in the high-voltage circuit. If high voltage exceeds specified limits, check each component specified on the chassis schematic and take corrective action.

2. Read and comply with all caution and safety-related notes on or inside the receiver cabinet, on the receiver chassis, or on the picture tube.
3. **Design Alteration Warning** - Do not alter or add to the mechanical or electrical design of this TV receiver. Design alterations and additions, including, but not limited to circuit modifications and the addition of items such as auxiliary audio and/or video output connections, might alter the safety characteristics of this receiver and create a hazard to the user. Any design alterations or additions will void the manufacturer's warranty and may make you, the servicer, responsible for personal injury or property damage resulting therefrom.
4. **Picture Tube Implosion Protection Warning** - The picture tube in this receiver employs integral implosion protection. For continued implosion protection, replace the picture tube only with one of the same type number. Do not remove, install, or otherwise handle the picture tube in any manner without first putting on shatterproof goggles equipped with side shields. People not so equipped must be kept safely away while picture tubes are handled. Keep the picture tube away from your body. Do not handle the picture tube by its neck. Some "in-line" picture tubes are equipped with a permanently attached deflection yoke; because of potential hazard, do not try to remove such "permanently attached" yokes from the picture tube.
5. **Hot Chassis Warning** -
 - a. Some TV receiver chassis are electrically connected directly to one conductor of the AC power cord and maybe safety-serviced without an isolation transformer only if the AC power plug is inserted so that the chassis is connected to the ground side of the AC power source. To confirm that the AC power plug is inserted correctly, with an AC voltmeter, measure between the chassis and a known

earth ground. If a voltage reading in excess of 1.0V is obtained, remove and reinsert the AC power plug in the opposite polarity and again measure the voltage potential between the chassis and a known earth ground.

- b. Some TV receiver chassis normally have 85V AC(RMS) between chassis and earth ground regardless of the AC plug polarity. This chassis can be safety-serviced only with an isolation transformer inserted in the power line between the receiver and the AC power source, for both personnel and test equipment protection.
 - c. Some TV receiver chassis have a secondary ground system in addition to the main chassis ground. This secondary ground system is not isolated from the AC power line. The two ground systems are electrically separated by insulation material that must not be defeated or altered.
6. Observe original lead dress. Take extra care to assure correct lead dress in the following areas:
 - a. near sharp edges,
 - b. near thermally hot parts-be sure that leads and components do not touch thermally hot parts,
 - c. the AC supply,
 - d. high voltage, and,
 - e. antenna wiring. Always inspect in all areas for pinched, out of place, or frayed wiring. Check AC power cord for damage.
 7. Components, parts, and/or wiring that appear to have overheated or are otherwise damaged should be replaced with components, parts, or wiring that meet original specifications. Additionally, determine the cause of overheating and/or damage and, if necessary, take corrective action to remove any potential safety hazard.
 8. **Product Safety Notice** - Some electrical and mechanical parts have special safety-related characteristics which are often not evident from visual inspection, nor can the protection they give necessarily be obtained by replacing them with components rated for higher voltage, wattage, etc.. Parts that have special safety characteristics are identified by a (▲) on schematics and in parts lists. Use of a substitute replacement that does not have the same safety characteristics as the recommended replacement part might create shock, fire, and/or other hazards. The product's safety is under review continuously and new instructions are issued whenever appropriate. Prior to shipment from the factory, our products are strictly inspected to confirm they comply with the recognized product safety and electrical codes of the countries in which they are to be sold. However, in order to maintain such compliance, it is equally important to implement the following precautions when a set is being serviced.

Precautions during Servicing

A. Parts identified by the () symbol are critical for safety.

Replace only with part number specified.

B. In addition to safety, other parts and assemblies are specified for conformance with regulations applying to spurious radiation. These must also be replaced only with specified replacements.

Examples: RF converters, RF cables, noise blocking capacitors, and noise blocking filters, etc.

C. Use specified internal wiring. Note especially:

- 1) Wires covered with PVC tubing
- 2) Double insulated wires
- 3) High voltage leads

D. Use specified insulating materials for hazardous live parts. Note especially:

- 1) Insulation Tape
- 2) PVC tubing
- 3) Spacers
- 4) Insulators for transistors.

E. When replacing AC primary side components (transformers, power cord, etc.), wrap ends of wires securely about the terminals before soldering.

F. Observe that the wires do not contact heat producing parts (heatsinks, oxide metal film resistors, fusible resistors, etc.)

G. Check that replaced wires do not contact sharp edged or pointed parts.

H. When a power cord has been replaced, check that 5~6 kg of force in any direction will not loosen it.

I. Also check areas surrounding repaired locations.

J. Use care that foreign objects (screws, solder droplets, etc.) do not remain inside the set.

K. Crimp type wire connector

The power transformer uses crimp type connectors which connect the power cord and the primary side of the transformer. When replacing the transformer, follow these steps carefully and precisely to prevent shock hazards.

Replacement procedure

1) Remove the old connector by cutting the wires at a point close to the connector.

Important: Do not re-use a connector (discard it).

2) Strip about 15 mm of the insulation from the ends of the wires. If the wires are stranded, twist the strands to avoid frayed conductors.

3) Align the lengths of the wires to be connected. Insert the wires fully into the connector.

4) Use the crimping tool to crimp the metal sleeve at the center position. Be sure to crimp fully to the complete closure of the tool.

L. When connecting or disconnecting the internal connectors, first, disconnect the AC plug from the AC supply outlet.

Safety Check after Servicing

Examine the area surrounding the repaired location for damage or deterioration. Observe that screws, parts and wires have been returned to original positions. Afterwards, perform the following tests and confirm the specified values in order to verify compliance with safety standards.

1. Clearance Distance

When replacing primary circuit components, confirm specified clearance distance (d) and (d') between soldered terminals, and between terminals and surrounding metallic parts. (See Fig. 1)

Table 1 : Ratings for selected area

AC Line Voltage	Region	Clearance Distance (d) (d')
110 to 130 V	USA or CANADA	≥ 3.2 mm (0.126 inches)

Note: This table is unofficial and for reference only. Be sure to confirm the precise values.

2. Leakage Current Test

Confirm the specified (or lower) leakage current between B (earth ground, power cord plug prongs) and externally exposed accessible parts (RF terminals, antenna terminals, video and audio input and output terminals, microphone jacks, earphone jacks, etc.) is lower than or equal to the specified value in the table below.

Measuring Method : (Power ON)

Insert load Z between B (earth ground, power cord plug prongs) and exposed accessible parts. Use an AC voltmeter to measure across both terminals of load Z . See Fig. 2 and following table.

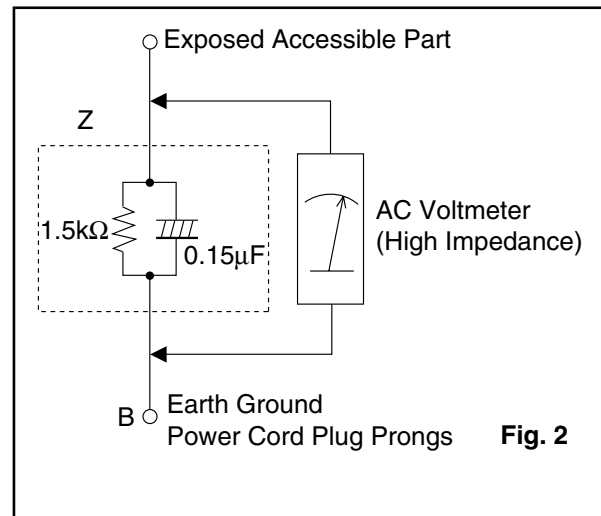
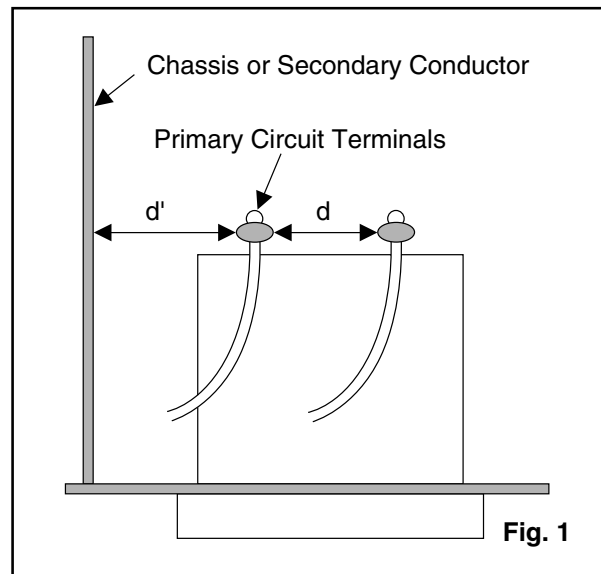

Table 2 : Leakage current ratings for selected areas

AC Line Voltage	Region	Load Z	Leakage Current (i)	Earth Ground (B) to:
110 to 130 V	USA	0.15 μ F CAP. & 1.5k Ω RES. connected in parallel	$i \leq 0.5$ mA rms	Exposed accessible parts

Note: This table is unofficial and for reference only. Be sure to confirm the precise values.

STANDARD NOTES FOR SERVICING

Circuit Board Indications

- a. The output pin of the 3 pin Regulator ICs is indicated as shown.

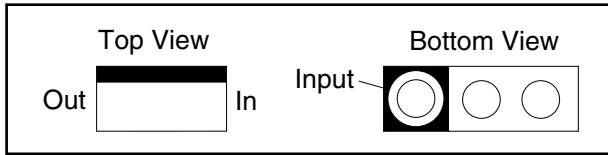

- b. For other ICs, pin 1 and every fifth pin are indicated as shown.

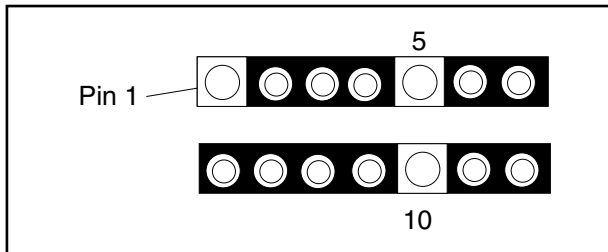

- c. The 1st pin of every male connector is indicated as shown.

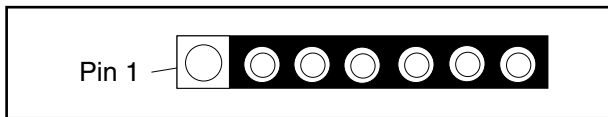

How to Remove / Install Flat Pack-IC

1. Removal

With Hot-Air Flat Pack-IC Desoldering Machine:

- (1) Prepare the hot-air flat pack-IC desoldering machine, then apply hot air to the Flat Pack-IC (about 5 to 6 seconds). (Fig. S-1-1)

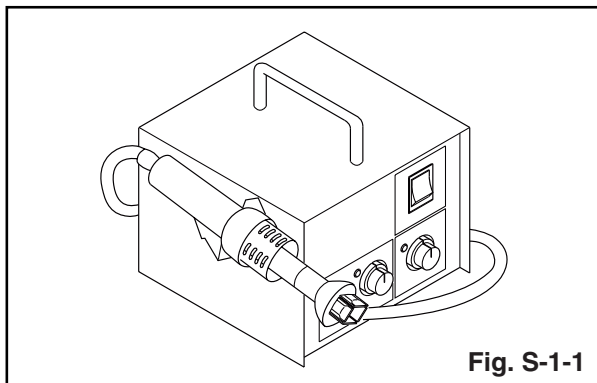

Fig. S-1-1

- (2) Remove the flat pack-IC with tweezers while applying the hot air.
- (3) Bottom of the flat pack-IC is fixed with glue to the CBA; when removing entire flat pack-IC, first apply soldering iron to center of the flat pack-IC and heat up. Then remove (glue will be melted). (Fig. S-1-6)
- (4) Release the flat pack-IC from the CBA using tweezers. (Fig. S-1-6)

Caution:

1. Do not supply hot air to the chip parts around the flat pack-IC for over 6 seconds because damage to the chip parts may occur. Put masking tape around the flat pack-IC to protect other parts from damage. (Fig. S-1-2)
2. The flat pack-IC on the CBA is affixed with glue, so be careful not to break or damage the foil of each pin or the solder lands under the IC when removing it.

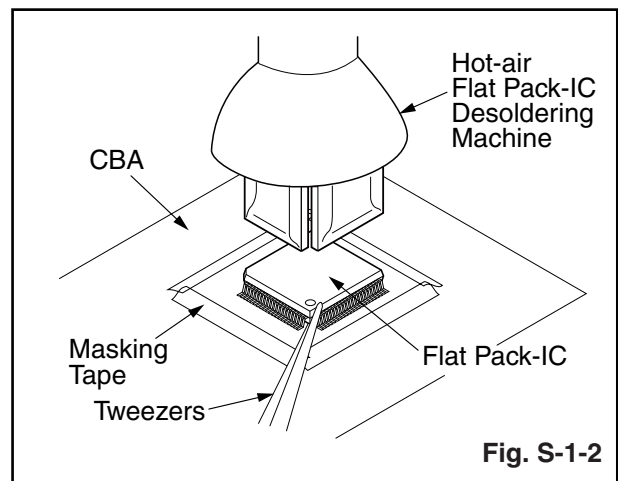
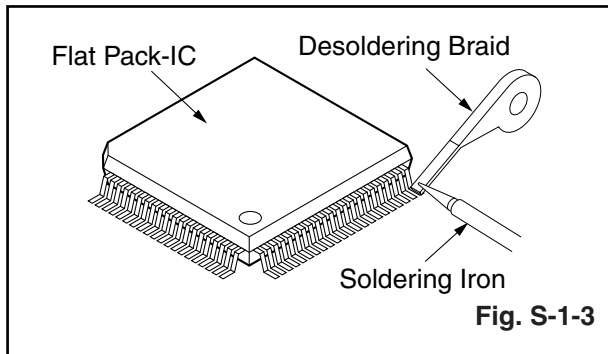

Fig. S-1-2

With Soldering Iron:

- (1) Using desoldering braid, remove the solder from all pins of the flat pack-IC. When you use solder flux which is applied to all pins of the flat pack-IC, you can remove it easily. (Fig. S-1-3)



- (2) Lift each lead of the flat pack-IC upward one by one, using a sharp pin or wire to which solder will not adhere (iron wire). When heating the pins, use a fine tip soldering iron or a hot air desoldering machine. (Fig. S-1-4)

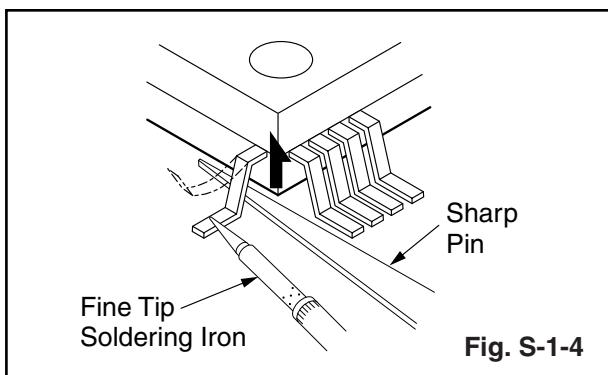

- (3) Bottom of the flat pack-IC is fixed with glue to the CBA; when removing entire flat pack-IC, first apply soldering iron to center of the flat pack-IC and heat up. Then remove (glue will be melted). (Fig. S-1-6)
- (4) Release the flat pack-IC from the CBA using tweezers. (Fig. S-1-6)

With Iron Wire:

- (1) Using desoldering braid, remove the solder from all pins of the flat pack-IC. When you use solder flux which is applied to all pins of the flat pack-IC, you can remove it easily. (Fig. S-1-3)
- (2) Affix the wire to a workbench or solid mounting point, as shown in Fig. S-1-5.
- (3) While heating the pins using a fine tip soldering iron or hot air blower, pull up the wire as the solder melts so as to lift the IC leads from the CBA contact pads as shown in Fig. S-1-5.
- (4) Bottom of the flat pack-IC is fixed with glue to the CBA; when removing entire flat pack-IC, first apply

soldering iron to center of the flat pack-IC and heat up. Then remove (glue will be melted). (Fig. S-1-6)

- (5) Release the flat pack-IC from the CBA using tweezers. (Fig. S-1-6)

Note:

When using a soldering iron, care must be taken to ensure that the flat pack-IC is not being held by glue. When the flat pack-IC is removed from the CBA, handle it gently because it may be damaged if force is applied.

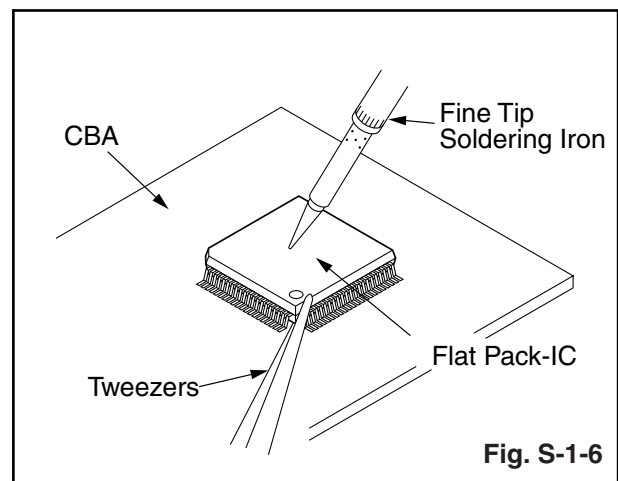
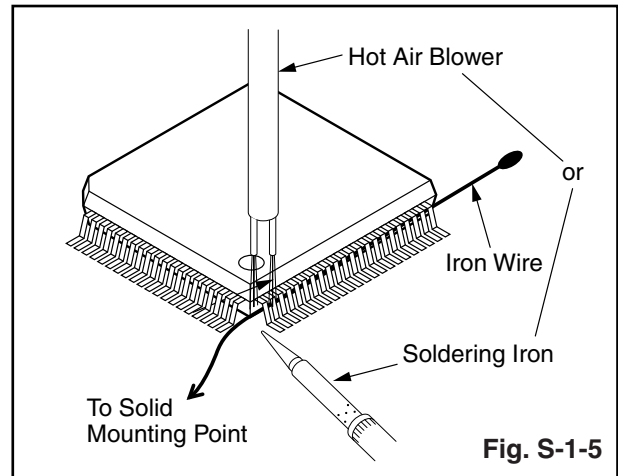

2. Installation

- (1) Using desoldering braid, remove the solder from the foil of each pin of the flat pack-IC on the CBA so you can install a replacement flat pack-IC more easily.
- (2) The "●" mark on the flat pack-IC indicates pin 1. (See Fig. S-1-7.) Be sure this mark matches the 1 on the PCB when positioning for installation. Then pre-solder the four corners of the flat pack-IC. (See Fig. S-1-8.)
- (3) Solder all pins of the flat pack-IC. Be sure that none of the pins have solder bridges.

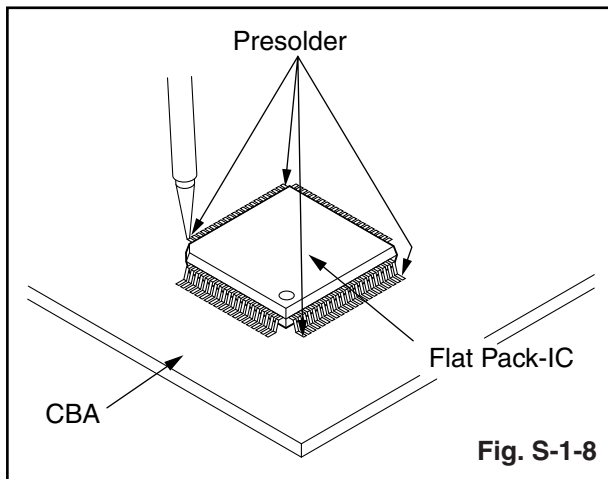
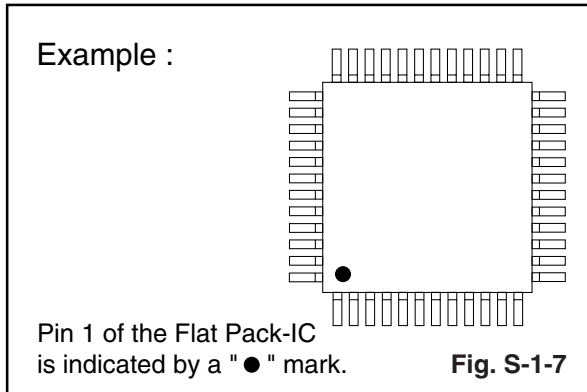

Instructions for Handling Semiconductors

Electrostatic breakdown of the semiconductors may occur due to a potential difference caused by electrostatic charge during unpacking or repair work.

1. Ground for Human Body

Be sure to wear a grounding band ($1M\Omega$) that is properly grounded to remove any static electricity that may be charged on the body.

2. Ground for Workbench

Be sure to place a conductive sheet or copper plate with proper grounding ($1M\Omega$) on the workbench or other surface, where the semiconductors are to be placed. Because the static electricity charge on clothing will not escape through the body grounding band, be careful to avoid contacting semiconductors with your clothing.

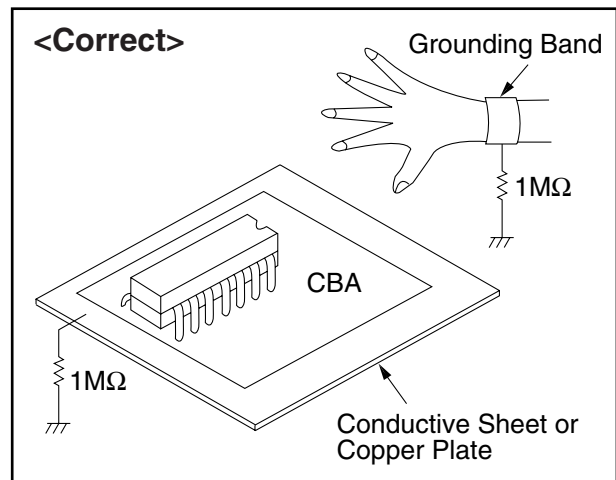
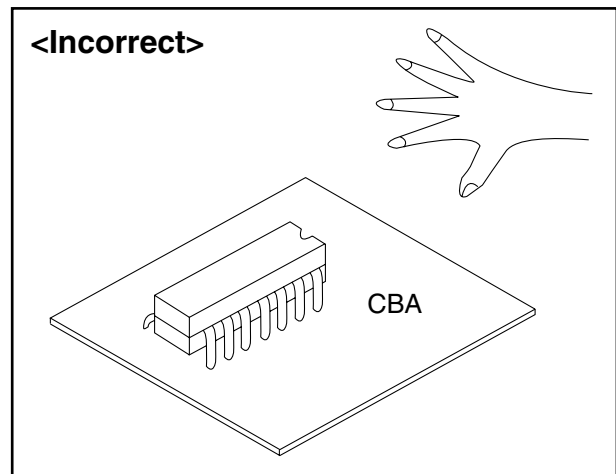

CABINET DISASSEMBLY INSTRUCTIONS

[C6413TD]

1. Disassembly Flowchart

This flowchart indicates the disassembly steps for the cabinet parts, and the CBA in order to gain access to item(s) to be serviced. When reassembling, follow the steps in reverse order. Bend, route and dress the cables as they were.

Caution !

When removing the CRT, be sure to discharge the Anode Lead of the CRT with the CRT Ground Wire before removing the Anode Cap.

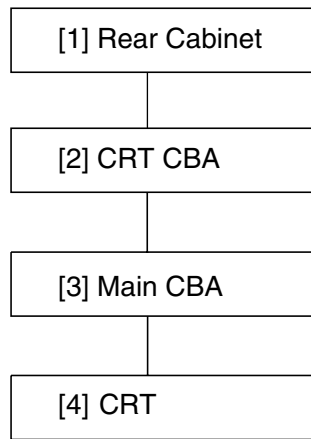

2. Disassembly Method

Step/ Loc. No.	Part	Removal		
		Fig. No	Remove/*unlock/ release/unplug/ unclamp/desolder	Note
[1]	Rear Cabinet	1,2	4(S-1)	1
[2]	CRT CBA	4,5	CN501	2
[3]	Main CBA	3,5	CN571	3
[4]	CRT	4	4(S-2), Anode Cap	4

↓ ↓ ↓ ↓ ↓
 (1) (2) (3) (4) (5)

Note :

- (1) Order of steps in procedure. When reassembling, follow the steps in reverse order. These numbers are also used as the Identification (location) No. of parts in figures.
- (2) Parts to be removed or installed.
- (3) Fig. No. showing procedure of part location
- (4) Identification of part to be removed, unhooked, unlocked, released, unplugged, unclamped, or desoldered.
S=Screw, P=Spring, L=Locking Tab, CN=Connector, *=Unhook, Unlock, Release, Unplug, or Desolder
2(S-2) = two Screws (S-2)
- (5) Refer to the following "Reference Notes in the Table.

Reference Notes in the Table

1. Removal of the Rear Cabinet. Remove screws 4(S-1), then slide the Rear Cabinet backward.
2. Removal of the CRT CBA. Disconnect CN501 then pull the CRT CBA backward.
3. Removal of the Main CBA. Disconnect CN571 on the Main CBA then slide the Main CBA backward.

Caution:

Discharge the Anode Lead of the CRT with the CRT Ground Wire before removing the Anode Cap.

4. Removal of the CRT. Remove screws 4(S-2) and Anode Cap then slide the CRT backward.

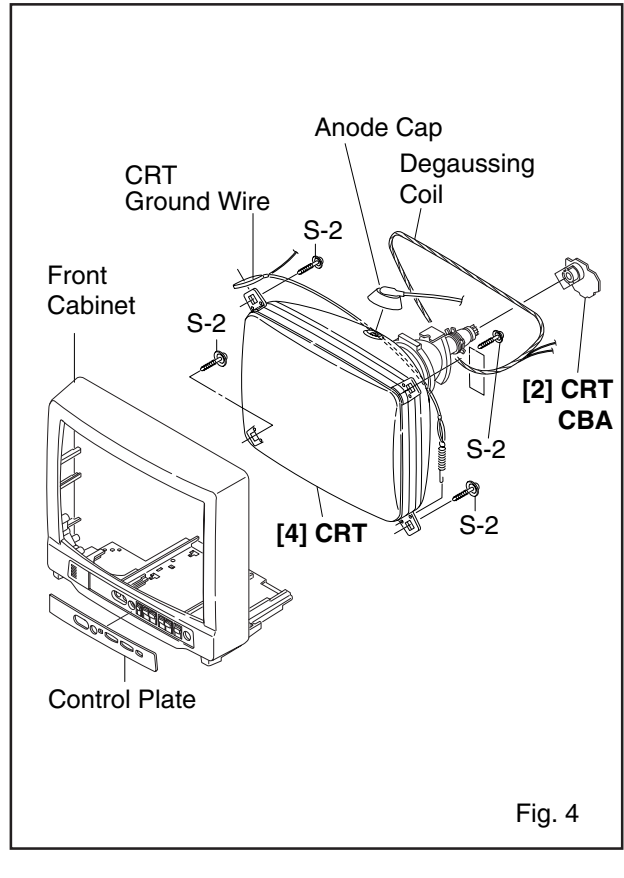
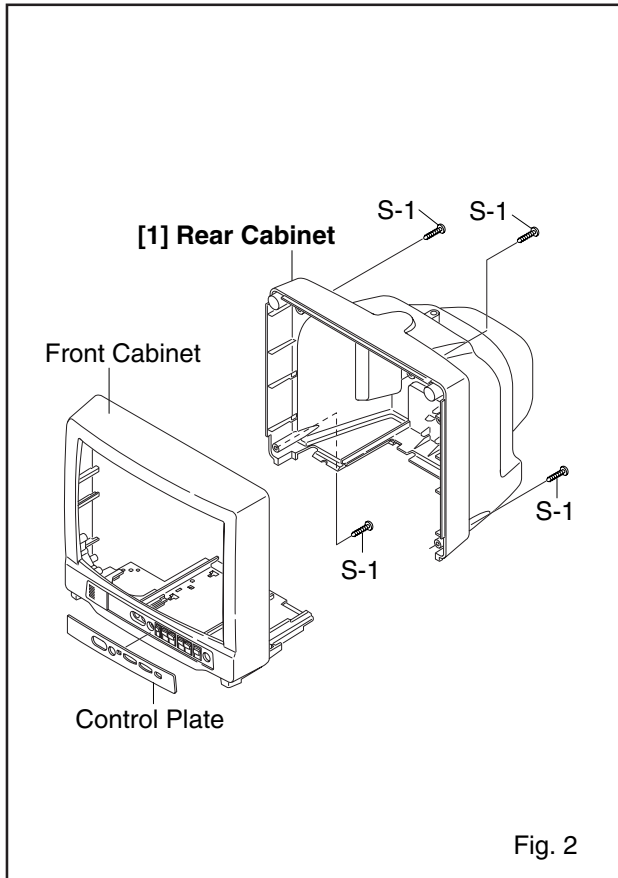
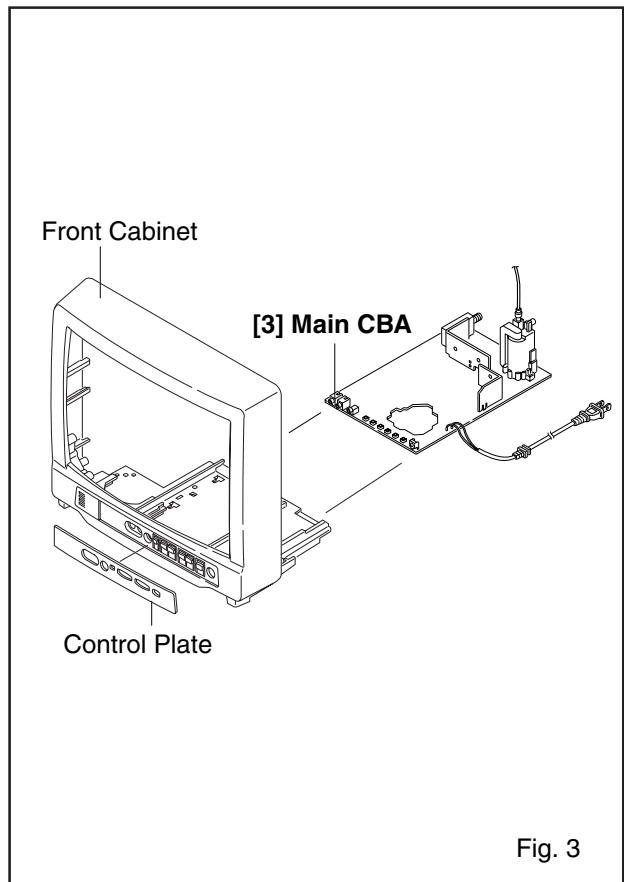
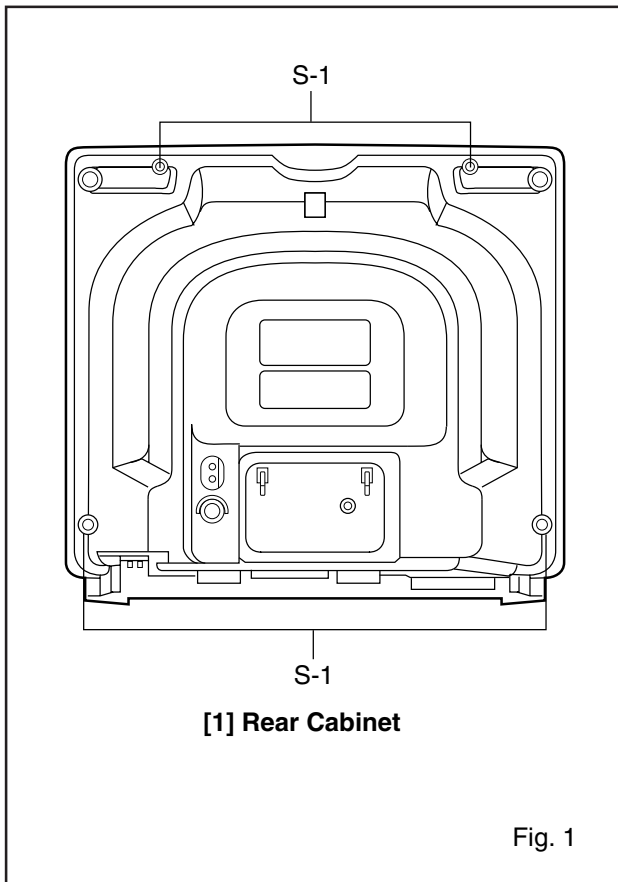

TV Cable Wiring Diagram

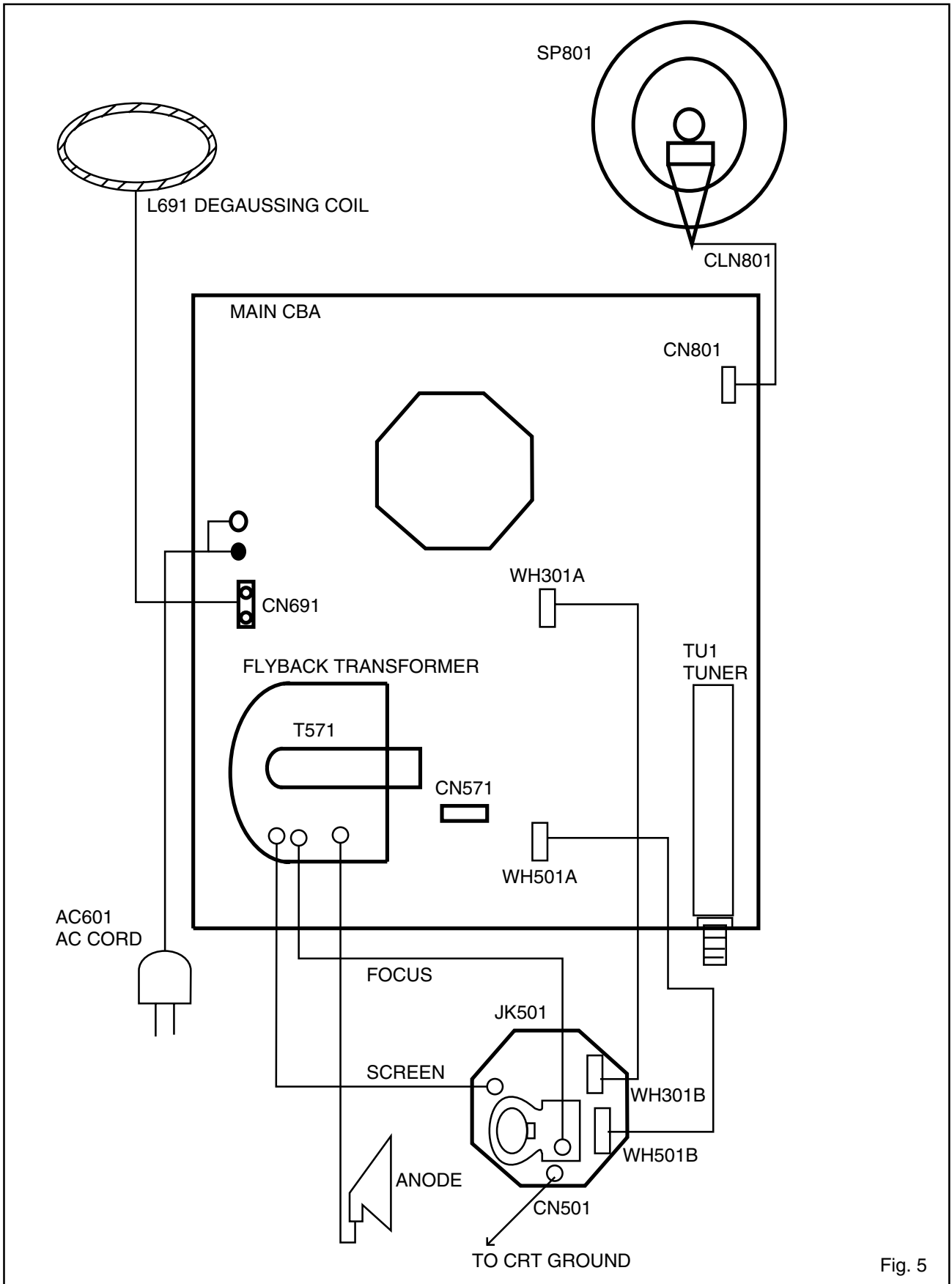

Fig. 5

[C6419TD]

1. Disassembly Flowchart

This flowchart indicates the disassembly steps for the cabinet parts, and the CBA in order to gain access to item(s) to be serviced. When reassembling, follow the steps in reverse order. Bend, route and dress the cables as they were.

Caution !

When removing the CRT, be sure to discharge the Anode Lead of the CRT with the CRT Ground Wire before removing the Anode Cap.

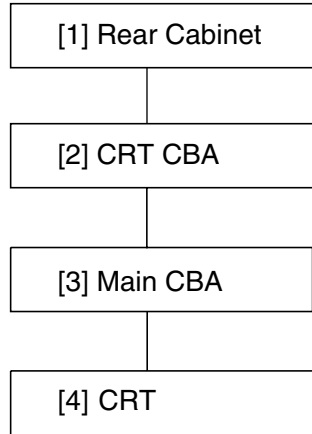

2. Disassembly Method

Step/ Loc. No.	Part	Removal		
		Fig. No	Remove/*unlock/ release/unplug/ unclamp/desolder	Note
[1]	Rear Cabinet	1,2	5(S-1), (S-3)	1
[2]	CRT CBA	4,5	CN501	2
[3]	Main CBA	3,5	CN571	3
[4]	CRT	4	4(S-2), Anode Cap	4

↓ ↓ ↓ ↓ ↓
 (1) (2) (3) (4) (5)

Note :

- (1) Order of steps in procedure. When reassembling, follow the steps in reverse order. These numbers are also used as the Identification (location) No. of parts in figures.
- (2) Parts to be removed or installed.
- (3) Fig. No. showing procedure of part location
- (4) Identification of part to be removed, unhooked, unlocked, released, unplugged, unclamped, or desoldered.
S=Screw, P=Spring, L=Locking Tab, CN=Connector, *=Unhook, Unlock, Release, Unplug, or Desolder
2(S-2) = two Screws (S-2)
- (5) Refer to the following "Reference Notes in the Table."

Reference Notes in the Table

1. Removal of the Rear Cabinet. Remove screws 5(S-1) and (S-3) then slide the Rear Cabinet backward.
2. Removal of the CRT CBA. Disconnect CN501 then pull the CRT CBA backward.
3. Removal of the Main CBA. Disconnect CN571 on the Main CBA then slide the Main CBA backward.

Caution:

Discharge the Anode Lead of the CRT with the CRT Ground Wire before removing the Anode Cap.

4. Removal of the CRT. Remove screws 4(S-2) and Anode Cap then slide the CRT backward.

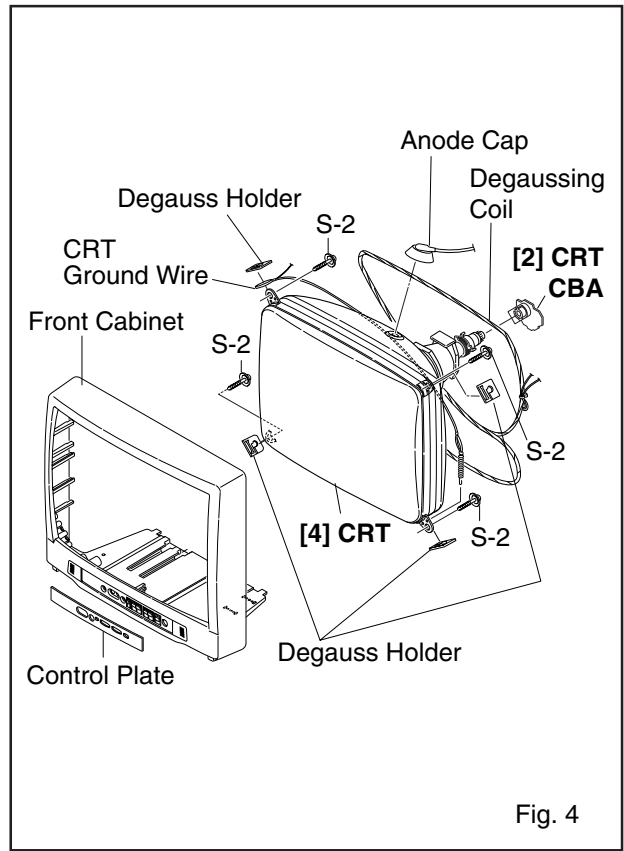
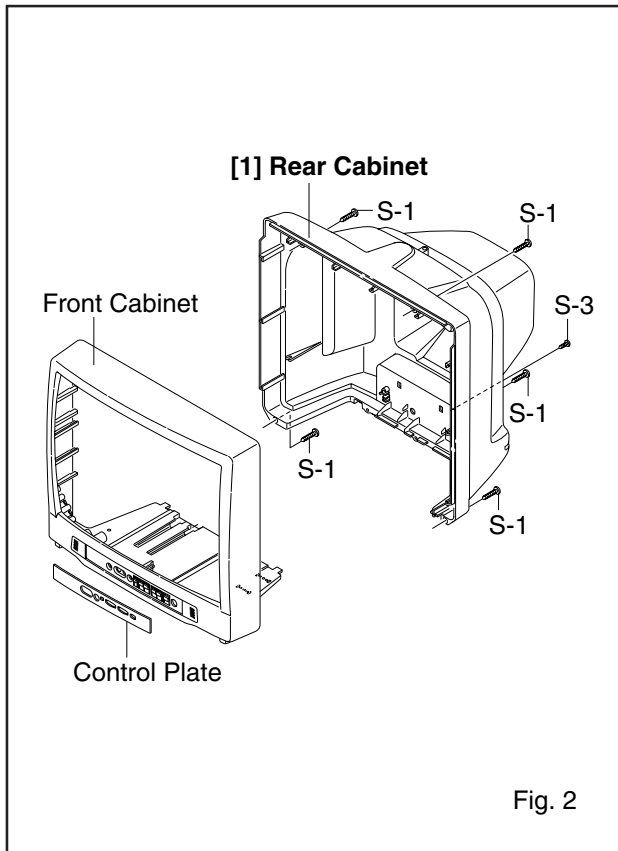
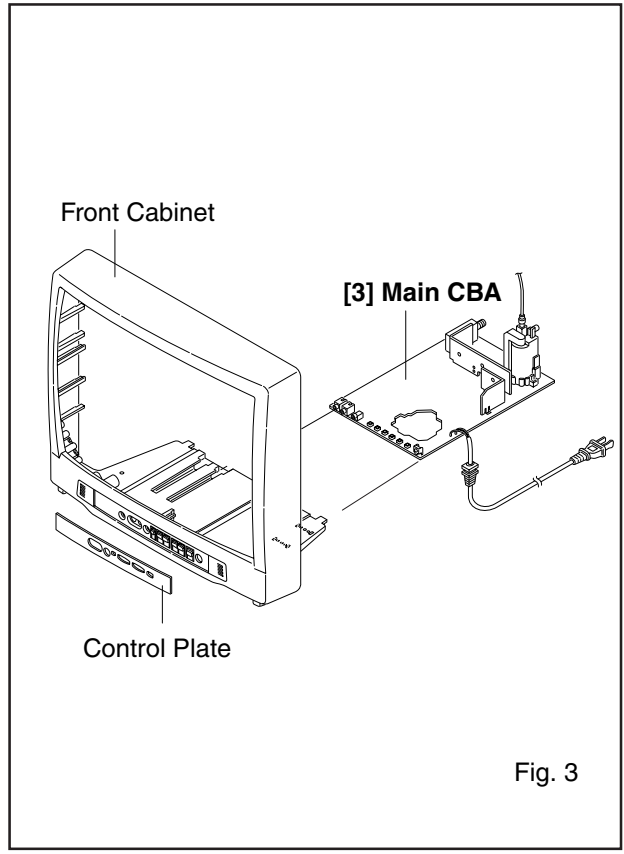
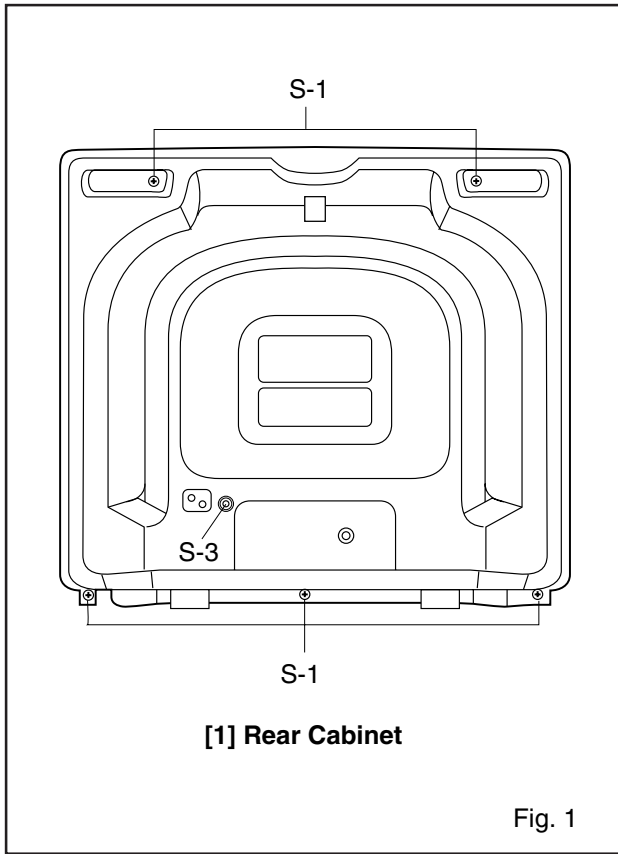

TV Cable Wiring Diagram

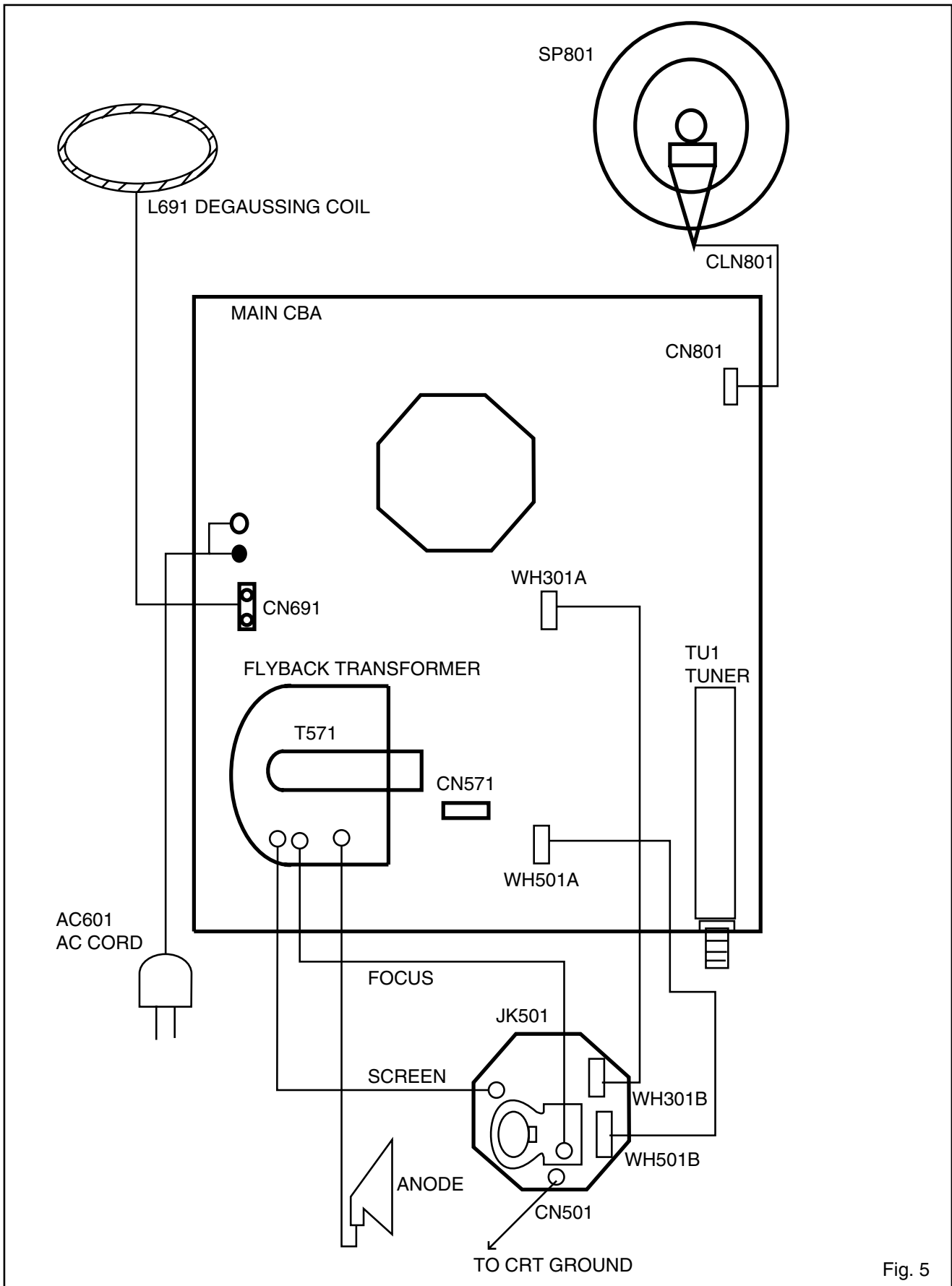

Fig. 5

ELECTRICAL ADJUSTMENT INSTRUCTIONS

General Note:

"CBA" is abbreviation for "Circuit Board Assembly."

NOTE:

Electrical adjustments are required after replacing circuit components and certain mechanical parts. It is important to perform these adjustments only after all repairs and replacements have been completed.

Also, do not attempt these adjustments unless the proper equipment is available.

Test Equipment Required

1. NTSC Pattern Generator (Color Bar W/White Window, Red Color, Dot Pattern, Gray Scale, Monoscope, Multi-Burst)
2. DC Voltmeter
3. Oscilloscope: Dual-trace with 10:1 probe, V-Range: 0.001~50V/Div, F-Range: DC~AC-60MHz
4. Plastic Tip Driver
5. Remote control unit: Part No. N0105UD or N0108UD
6. DC power supply 13.2V/5A
7. Color Analyzer

How to make service remote control unit:

1. Prepare normal remote control unit. (Part No. N0105UD or N0108UD) Remove 3 Screws from the back lid. (Fig. 1-1)
2. Add J1 (Jumper Wire) to the remote control CBA. (Fig. 1-2)

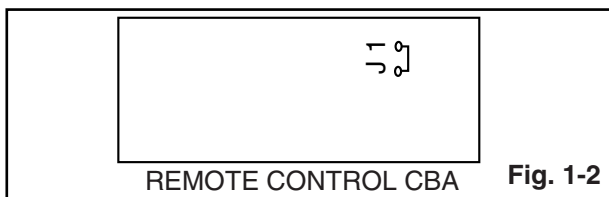
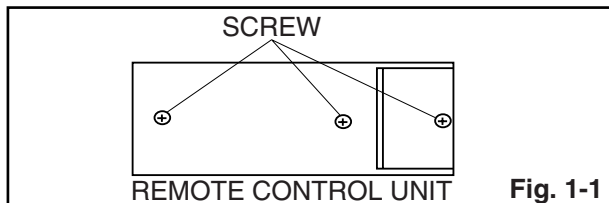

How to set up the service mode:

Service mode:

1. Use the service remote control unit.
2. Turn the power on. (Use main power on the TV unit.)
3. Press "SLEEP" button on the service remote control unit. Version of micro computer will display on the CRT. (Ex: 050-0.11)
4. When CPU version is 050-0.11: Check the display on the lower left is "10" and if it is not "10," set it at "10" according to "3-1 7F, FRENCH, ACCESS CODE, STEREO, VIDEO TONE, FM-MODE, V-OUT."

1. DC 105V Adjustment (C6413TD)

Purpose: To obtain correct operation.

Symptom of Misadjustment: The picture is dark and the unit does not operate correctly.

Test Point	Adj. Point	Mode	Input
TP601 TP300 (GND)	VR661	---	---
Tape	M. EQ.	Spec.	
---	DC Voltmeter	+105±0.5V DC.	

Note: TP601, TP300 (GND), VR661 --- Main CBA

1. Connect DC Volt Meter to TP601 and TP300 (GND.)
2. Adjust VR661 so that the voltage of TP601 becomes +105±0.5V DC.

1. DC 114V Adjustment (C6419TD)

Purpose: To obtain correct operation.

Symptom of Misadjustment: The picture is dark and the unit does not operate correctly.

Test Point	Adj. Point	Mode	Input
TP601 TP300 (GND)	VR661	---	---
Tape	M. EQ.	Spec.	
---	DC Voltmeter	+114±0.5V DC.	

Note: TP601, TP300 (GND), VR661 --- Main CBA

1. Connect DC Volt Meter to TP601 and TP300(GND).
2. Adjust VR661 so that the voltage of TP601 becomes +114±0.5V DC.

2. Black Stretch Control Adjustment

Purpose: To show the fine black color.

Symptom of Misadjustment: Black color will not appear correctly.

Note: Use service remote control unit.

1. Enter the Service mode. (See page 5-1)
2. Press "6" button on the service remote control unit. "B-S" is indicated.
3. Press "CH ▲ / ▼" buttons on the service remote control unit so that display will change "OFF," "0," "1," "2" and "3." Then choose "B-S OFF."
4. Press "6" button on the service remote control unit. "B-S*2" is indicated.
5. Press "CH ▲ / ▼" buttons on the service remote control unit so that display will change "0" and "1." Then choose "B-S*2 0."
6. Turn the power off and on again, using the main power button on the TV unit.

3-1. Setting for Data Values

General

1. Enter the Service mode. (See page 5-1)
2. To select the Data Value, press "VOL ▼" button on the service remote control unit.
3. To set the following each data value, press "CH ▲ / ▼" buttons on the service remote control unit.

7F --- set to 7F

FRENCH --- set to ON

ACCESS CODE --- set to OFF

STEREO --- set to OFF

VIDEO TONE --- set to OFF

FM-MODE --- set to OFF

V-OUT --- set to OFF

3-2. Setting for CONTRAST, COLOR, TINT, V-TINT and SHARP data Values

General

1. Enter the Service mode. (See page 5-1)
2. Press "MENU" button on the service remote control unit. Display changes "BRIGHT," "CONTRAST," "COLOR," "TINT," "V-TINT" and "SHARP" cyclically when "MENU" button is pressed.

CONTRAST (CNT)

1. Press "MENU" button on the service remote control unit. Then select "CONTRAST" (CNT) display.
2. Press "CH ▲ / ▼" buttons on the service remote control unit so that the value of "CONTRAST" (CNT) becomes 84.

COLOR (CLR)

1. Press "MENU" button on the service remote control unit. Then select "COLOR" (CLR) display.
2. Press "CH ▲ / ▼" buttons on the service remote control unit so that the value of "COLOR" (CLR) becomes 58.

TINT (TNT)

1. Press "MENU" button on the service remote control unit. Then select "TINT" (TNT) display.
2. Press "CH ▲ / ▼" buttons on the service remote control unit so that the value of "TINT" (TNT) becomes 57.

V-TINT (V-TNT)

1. Press "MENU" button on the service remote control unit. Then select "V-TINT" (V-TNT) display.
2. Press "CH ▲ / ▼" buttons on the service remote control unit so that the value of "V-TINT" (V-TNT) becomes 60.

SHARP (SHARP)

1. Press "MENU" button on the service remote control unit. Then select "SHARP" (SHARP) display.
2. Press "CH ▲ / ▼" buttons on the service remote control unit so that the value of "SHARP" (SHARP) becomes 40.

Note: BRIGHT data value does not need to be adjusted at this moment.

4. Black Level Adjustment

Purpose: Set Black Level

Symptom of Misadjustment: If Black level is incorrect, Proper brightness can not be obtained by adjusting the Brightness Control.

Note: TP300 (GND,) D316 (Cathode) --- MAIN CBA

1. Enter the Service mode. (See page 5-1.)
2. Press "MENU" button on the service remote control unit and select "BRT" mode. (Display changes "BRT," "CNT," "CLR" and "TNT" cyclically when MENU button is pressed.)
3. Press "CH ▲ / ▼" buttons on the service remote control unit so that the value of "BRT" becomes 128.
4. Turn the power off and on again, using the main power button on the TV unit.

5. V. Size Adjustment

Purpose: To obtain correct vertical width of screen image.

Symptom of Misadjustment: If V.Size is incorrect, vertical size of image on the screen may not be properly displayed.

Test Point	Adj. Point	Mode	Input
---	Screen Control CH ▲ / ▼ buttons [V-S] Mode	RF	Monoscope
Tape	M. EQ.	Spec.	
---	Monoscope	90±5%	

Note: Use service remote control unit.

1. Operate the unit for at least 20 minutes.
2. Enter the Service mode. (See page 5-1)
3. Receive the Monoscope Pattern.
4. Press "9" button on the service remote control unit and select "V-S" mode. (Display changes "V-S" and "V-P" cyclically when "9" button is pressed.)
5. Press "CH ▲ / ▼" buttons on the service remote control unit so that the monoscope pattern will be 90±5% of display size and the circle is round.
6. Turn the power off and on again, using the main power button on the TV unit.

6. V. Position Adjustment

Purpose: To obtain correct vertical width of screen image.

Symptom of misadjustment: If V. Position is incorrect, vertical height of image on the screen may not be properly displayed.

Test Point	Adj. Point	Mode	Input
---	Screen Control CH ▲ / ▼ buttons [V-P] Mode	RF	Monoscope
Tape	M. EQ.	Spec.	
---	Monoscope	90±5%	

Note: Use service remote control unit

1. Operate the unit for at least 20 minutes.
2. Enter the Service Mode. (See page 5-1)
3. Receive the Monoscope Pattern.
4. Press "9" button on the service remote control unit and select "V-P" mode. (Display change "V-S" and "V-P" cyclically when "9" button is pressed.)
5. Press "CH ▲ / ▼" buttons on the service remote control unit so that the top and bottom of the monoscope pattern will be equal of each other.
6. Turn the power off and on again, using the main power button on the TV unit.

7. H. Position Adjustment

Purpose: To obtain correct horizontal position of screen image.

Symptom of Misadjustment: If H. Position is incorrect, horizontal position of image on the screen may not be properly displayed.

Test Point	Adj. Point	Mode	Input
---	Screen Control CH ▲ / ▼ buttons [H-P] Mode	RF	Monoscope
Tape	M. EQ.	Spec.	
---	Monoscope	90±5%	

Note: Use service remote control unit

1. Operate the unit for at least 20 minutes.
2. Enter the Service mode. (See page 5-1)
3. Receive the Monoscope Pattern.
4. Press "8" button on the remote control unit and select "H-P" mode.
5. Press "CH ▲ / ▼" buttons on the service remote control unit so that the monoscope pattern will be 90±5% of display size and the circle is round.
6. Turn the power off and on again, using the main power button on the TV unit.

8. Cut-off Adjustment

Purpose: To adjust the beam current of R, G, B, and screen voltage.

Symptom of Misadjustment: White color may be reddish, greenish or bluish.

Test Point	Adj. Point	Mode	Input
---	Screen-Control CH ▲ / ▼ buttons	RF	Black Raster
Tape	M. EQ.	Spec.	
---	Pattern Generator	See Reference Notes below.	

Figure

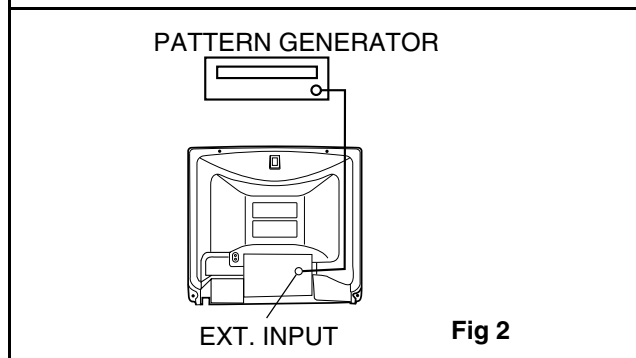

Note: Screen Control FBT --- Main CBA
FBT= Fly Back Transformer
Use service remote control unit

1. Degauss the CRT and allow CRT to operate for 20 minutes before starting the alignment.
2. Input the Black Raster Signal from RF Input.
3. Enter the Service mode. (See page 5-1)
4. Press "VOL ▼" button on the service remote control unit and select "C/D" mode. (Display changes "C/D," "VCO," "7F" and "FRENCH" cyclically when "VOL ▼" button is pressed.) then press "1." The display will momentarily show "CUT OFF R" (R= Red.) Now there should be a horizontal line across the center of the picture tube. If needed gradually turn the screen control on the flyback, clockwise until the horizontal line appears. Adjust the Red Cut off by pressing the "CH ▲ / ▼" buttons. Proceed to Step 5 when the Red Cut off adjustment is done.
5. Press the "2" button. The display will momentarily show "CUT OFF G" (G=Green.) Adjust the Green Cut off by pressing the "CH ▲ / ▼" buttons. Proceed to step 6 when the Green Cut off adjustment is done.
6. Press the "3" button. The display will momentarily show "CUT OFF B" (B=Blue.) Adjust the Blue cut off by pressing the "CH ▲ / ▼" buttons. When done with steps 4, 5 and 6 the horizontal line should be pure white if not, then attempt the Cut off adjustment again.

9. White Balance Adjustment

Purpose: To mix red, green and blue beams correctly for pure white.

Symptom of Misadjustment: White becomes bluish or reddish.

Test Point	Adj. Point	Mode	Input
Screen	Screen-Control CH ▲ / ▼ buttons	RF	White Raster (APL 100%)
Tape	M. EQ.	Spec.	
	Pattern Generator, Color analyzer	See below	

Figure

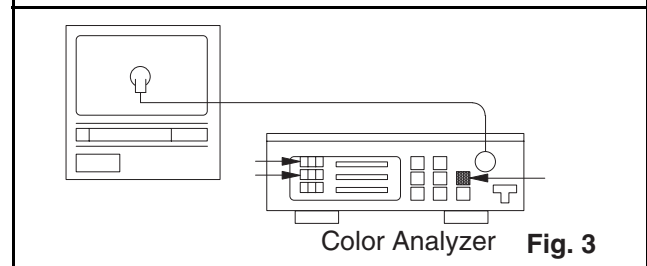

Note: Use service remote control unit

1. Operate the unit more than 20 minutes.
2. Face the unit to east. Degauss the CRT using De-gaussing Coil.
3. Input the White Raster (APL 100%).
4. Set the color analyzer to the CHROMA mode and after zero point calibration, bring the optical receptor to the center on the tube surface (CRT).
5. Enter the Service mode. Press "VOL ▼" button on the service remote control unit and select "C/D" mode. (Display changes "C/D," "VCO," "7F" and "FRENCH" cyclically when "VOL ▼" button is pressed.) Then press "8" button on the Service remote control Unit.
6. Press "4" button on the service remote control unit for Red adjustment. Press "5" button on the service remote control unit for Blue adjustment.
7. In each color mode, press "CH ▲ / ▼" button to adjust the values of color.
8. Adjusting Red and Blue color so that the temperature becomes 9200K (x: 286 / y: 294) ±3%.
9. At this time, re-check that Horizontal line is white. If not, Re-adjust Cut-off Adjustment until the Horizontal Line becomes pure white.
10. Turn off and on again to return to normal mode. Receive APL 100% white signal and Check Chroma temperatures become 9200K (x: 286 / y: 294) ±3%.

Note: Confirm that Cut Off Adj. is correct after this adjustment, and attempt Cut Off Adj. if needed.

10. Sub-Brightness Adjustment

Purpose: To get proper brightness.

Symptom of Misadjustment: If Sub-Brightness is incorrect, proper brightness cannot be obtained by adjusting the Brightness Control.

Test Point	Adj. Point	Mode	Input
---	CH ▲ / ▼ buttons	RF	IQW
Tape	M. EQ.	Spec.	
---	Pattern Generator	See below	
Figure			

Note: IQW Setup level --- 7.5 IRE
Use service remote control unit

1. Enter the Service mode. (See page 5-1)
Then input IQW signal from RF Input.
2. Press "MENU" button on the service remote control unit and Select "BRT" mode. (Display changes "BRT," "CNT," "CLR," and "TNT" cyclically when MENU button is pressed.) Press "CH ▲ / ▼" buttons so that the bar is just visible (See above figure).
3. Turn the power off and on again, using the main power button on the TV unit.

11. Focus Adjustment

Purpose: Set the optimum Focus.

Symptom of Misadjustment: If Focus Adjustment is incorrect, blurred images are shown on the display.

Test Point	Adj. Point	Mode	Input
---	Focus Control	RF	Monoscope
Tape	M. EQ.	Spec.	
---	Pattern Generator	See below	

Note: Focus VR (FBT) --- Main CBA,
FBT= Fly Back Transformer

1. Operate the unit more than 30 minutes
2. Face the unit to the East and degauss the CRT using a degaussing coil.
3. Input the Monoscope Pattern.
4. Adjust the Focus Control on the FBT to obtain clear picture.

The following 2 adjustments normally are not attempted in the field. Only when replacing the CRT then adjust as a preparation.

12. Purity Adjustment

Purpose: To obtain pure color.

Symptom of Misadjustment: If Color Purity Adjustment is incorrect, large areas of color may not be properly displayed.

Test Point	Adj. Point	Mode	Input
---	Deflection Yoke Purity Magnet	---	Red Color
Tape	M. EQ.	Spec.	
---	Pattern Generator	See below.	
Figure			

1. Set the unit facing East.
2. Operate the unit for over 30 minutes before adjusting.
3. Fully degauss the unit using an external degaussing coil.
4. Loosen the screw on the Deflection Yoke Clamper and pull the Deflection Yoke back away from the screen. (See Fig. 6)
5. Loosen the Ring Lock and adjust the Purity Magnets so that a red field is obtained at the center of the screen. Tighten Ring Lock. (See Fig. 5, 6)
6. Slowly push the Deflection Yoke toward bell of CRT and set it where a uniform red field is obtained.
7. Tighten the clamp screw on the Deflection Yoke.

13. Convergence Adjustment

Purpose: To obtain proper convergence of red, green and blue beams.

Symptom of Misadjustment: If Convergence Adjustment is incorrect, the edge of white letters may have color edges.

5. Fix the Deflection Yoke by carefully inserting the DY Wedges between CRT and Deflection Yoke.

Test Point	Adj. Point	Mode	Input
---	C.P. Magnet (RB, C.P. Magnet (RB-G, Deflection Yoke	---	Dot Pattern or Crosshatch
Tape	M. EQ.	Spec.	
---	Pattern Generator	See below.	

Figure

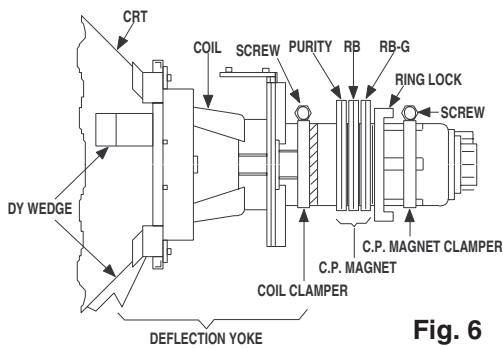

Fig. 6

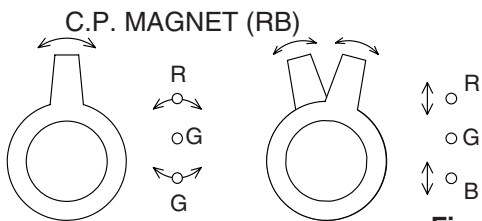

Fig. 7

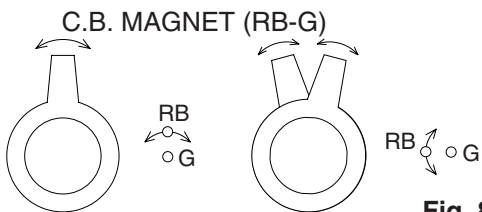
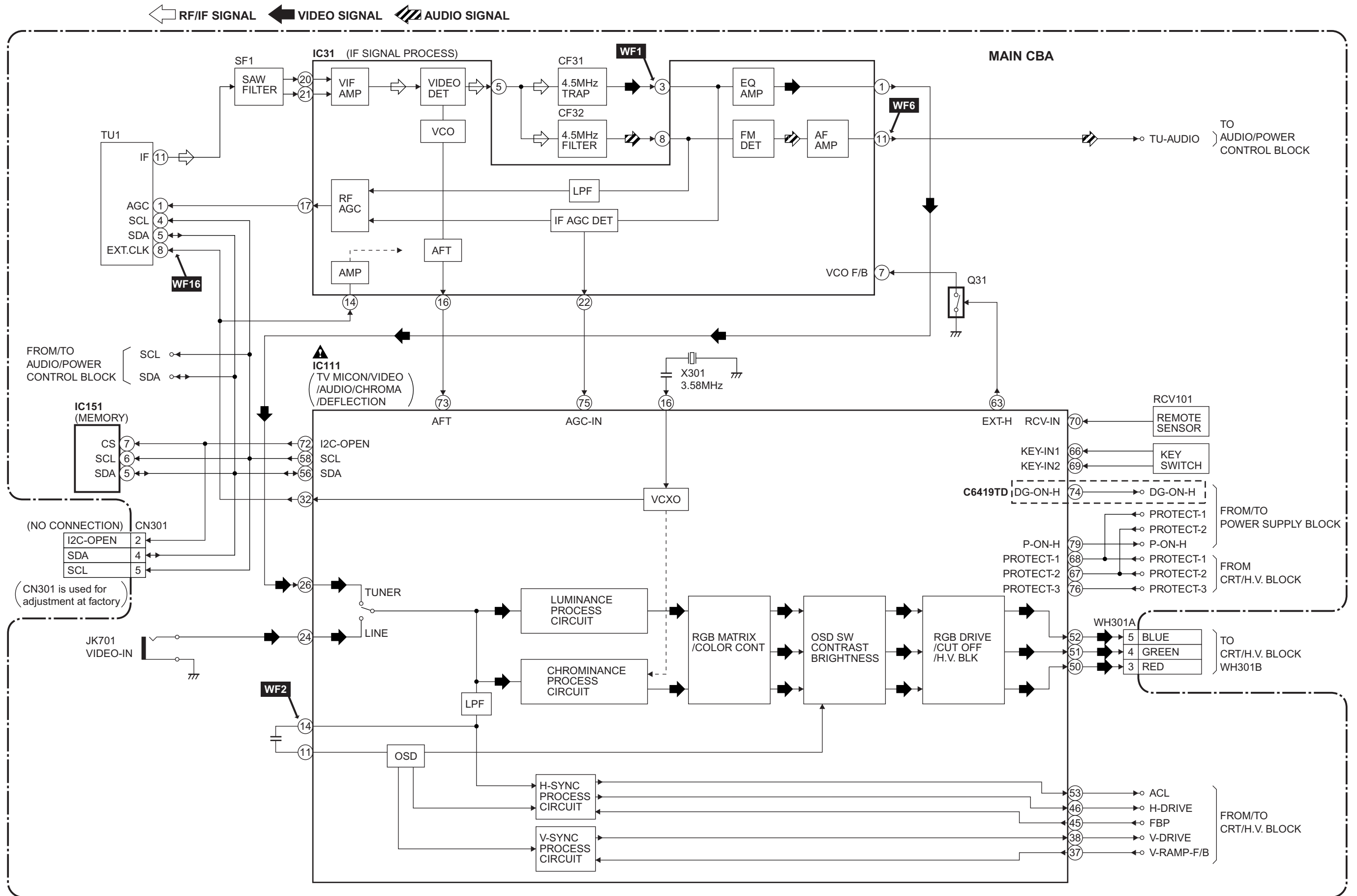

Fig. 8

1. Loosen the Ring Lock and align red with blue dots or Crosshatch at the center of the screen by rotating (RB) C.P. Magnets. (See Fig. 7)
2. Align red / blue with green dots at the center of the screen by rotating (RB-G) C.P. Magnet. (See Fig. 8)
3. Fix the C.P. Magnets by tightening the Ring Lock.
4. Remove the DY Wedges and slightly tilt the Deflection Yoke horizontally and vertically to obtain the best overall convergence.

BLOCK DIAGRAMS

IF/Video/System Control Block Diagram



Audio/Power Control Block Diagram

 AUDIO SIGNAL

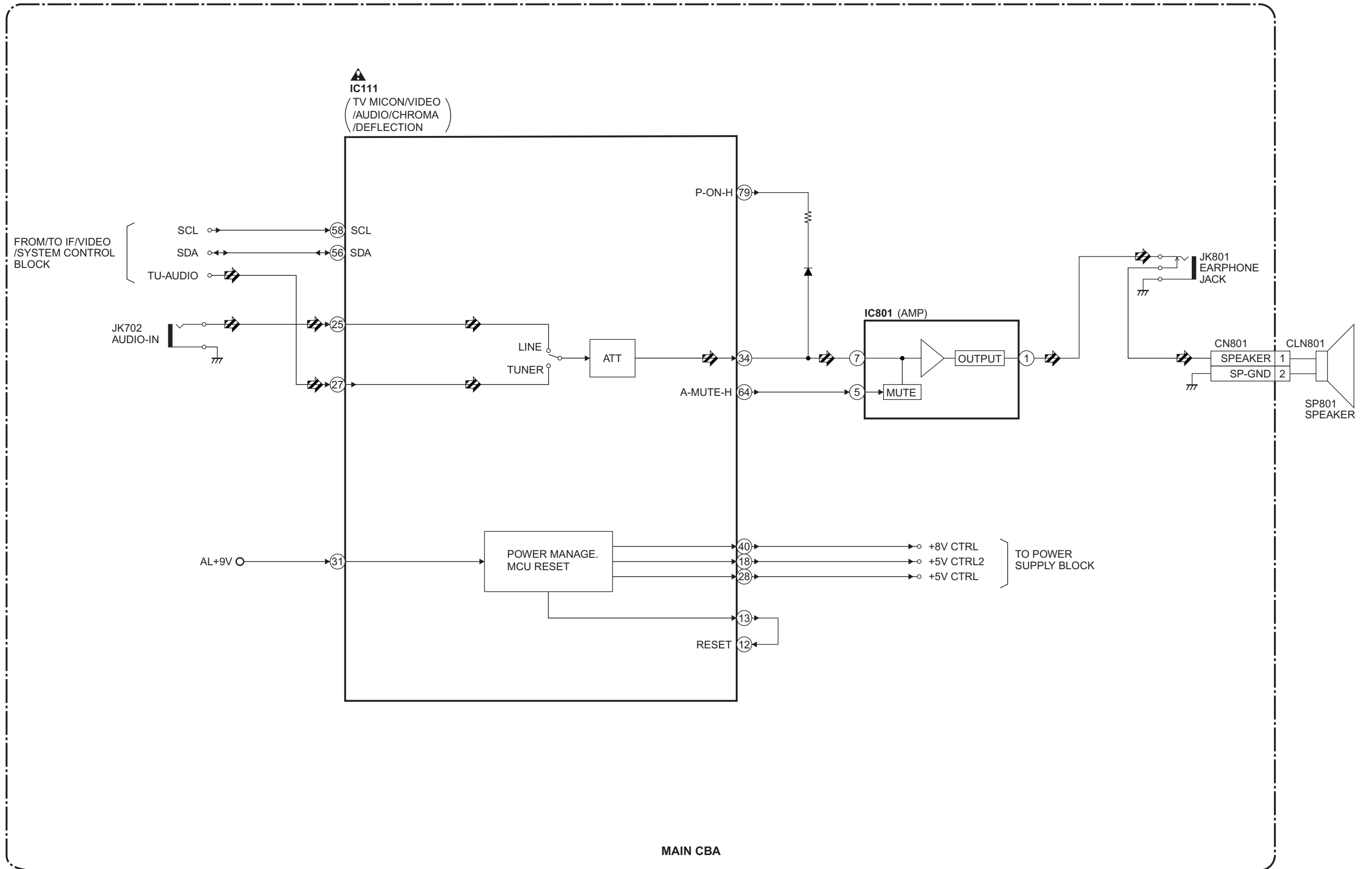

CRT/H.V. Block Diagram

← VIDEO SIGNAL

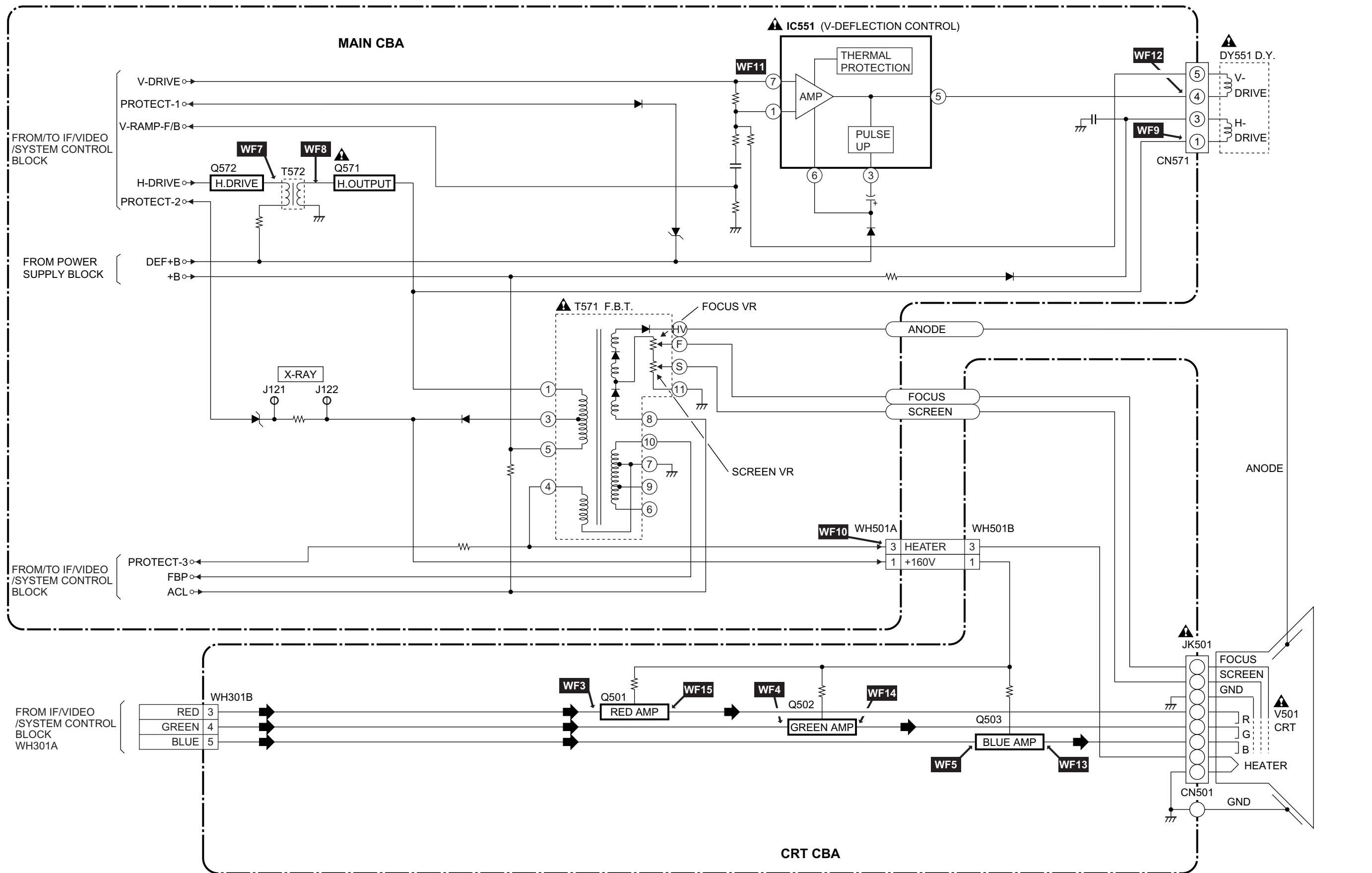

Power Supply Block Diagram

CAUTION !

Fixed voltage (or Auto voltage selectable) power supply circuit is used in this unit.
If Main Fuse (F601) is blown, check to see that all components in the power supply circuit are not defective before you connect the AC plug to the AC power supply.
Otherwise it may cause some components in the power supply circuit to fail.

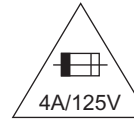

CAUTION: FOR CONTINUED PROTECTION AGAINST RISK OF FIRE,
REPLACE ONLY WITH SAME TYPE 4 A, 125V FUSE.
ATTENTION: UTILISER UN FUSIBLE DE RECHANGE DE MÊME TYPE DE 4A, 125V.

NOTE :
The voltage for parts in hot circuit is measured using hot GND as a common terminal.

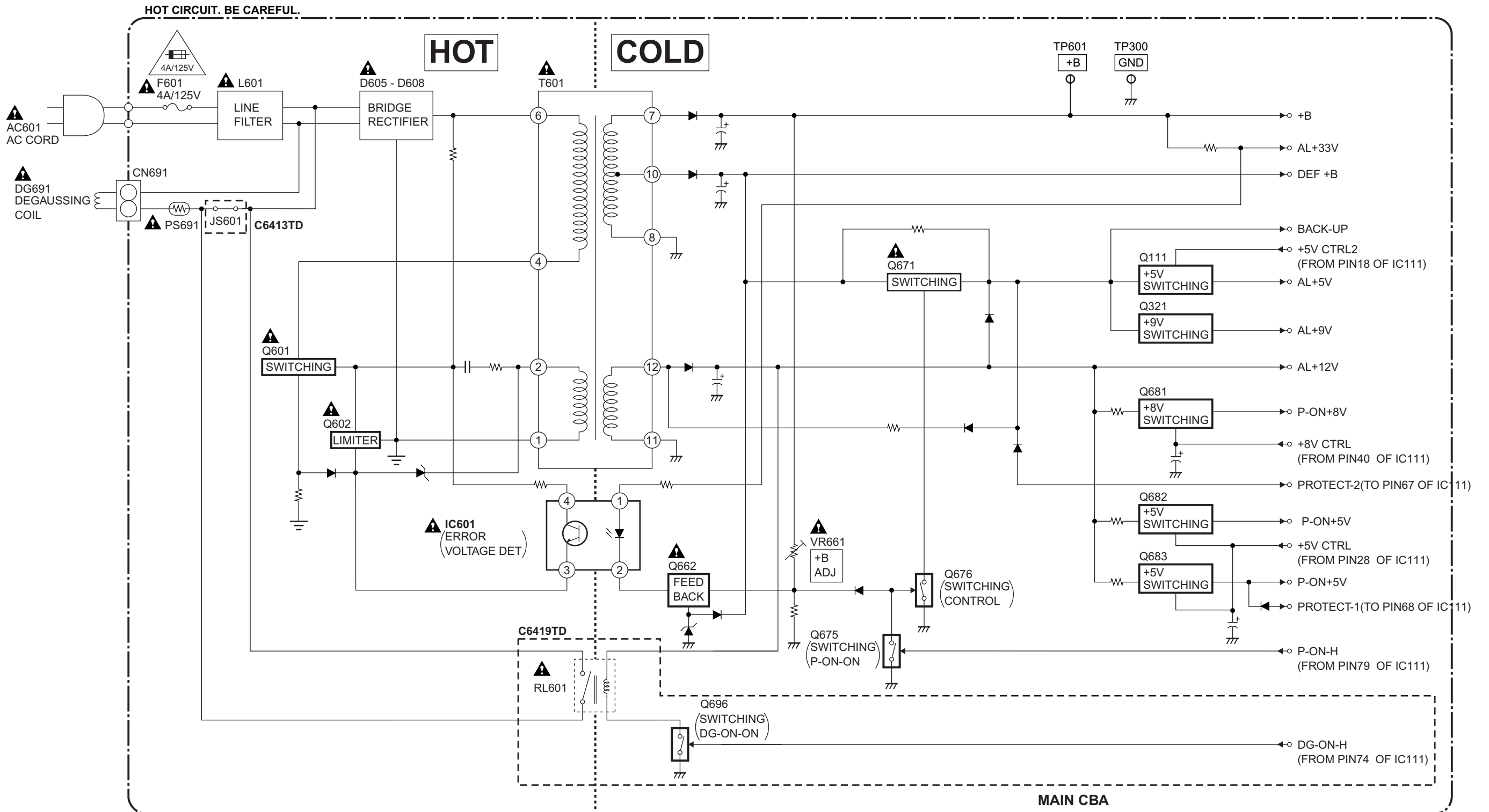

SCHEMATIC DIAGRAMS / CBA'S AND TEST POINTS

Standard Notes

Many electrical and mechanical parts in this chassis have special characteristics. These characteristics often pass unnoticed and the protection afforded by them cannot necessarily be obtained by using replacement components rated for higher voltage, wattage, etc. Replacement parts that have these special safety characteristics are identified in this manual and its supplements; electrical components having such features are identified by the mark "▲" in the schematic diagram and the parts list. Before replacing any of these components, read the parts list in this manual carefully. The use of substitute replacement parts that do not have the same safety characteristics as specified in the parts list may create shock, fire, or other hazards.

Note:

1. Do not use the part number shown on these drawings for ordering. The correct part number is shown in the parts list, and may be slightly different or amended since these drawings were prepared.
2. All resistance values are indicated in ohms ($K=10^3$, $M=10^6$).
3. Resistor wattages are 1/4W or 1/6W unless otherwise specified.
4. All capacitance values are indicated in μF ($P=10^{-6}\mu F$).
5. All voltages are DC voltages unless otherwise specified.

Note of Capacitors:

ML --- Mylar Cap. PP --- Metallized Film Cap. SC --- Semiconductor Cap. L --- Low Leakage type

Temperature Characteristics of Capacitors are noted with the following:

B --- $\pm 10\%$ CH --- $0\pm 60\text{ppm}/^\circ\text{C}$ CSL --- $+350\sim -1000\text{ppm}/^\circ\text{C}$

Tolerance of Capacitors are noted with the following:

Z --- $+80\sim -20\%$

Note of Resistors:

CEM --- Cement Res. MTL --- Metal Res. F --- Fuse Res.

Capacitors and transistors are represented by the following symbols.

CBA Symbols

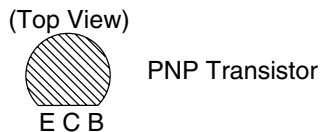
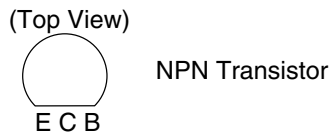
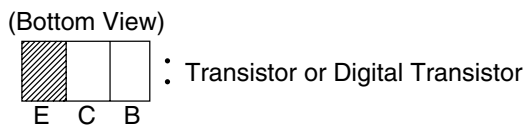
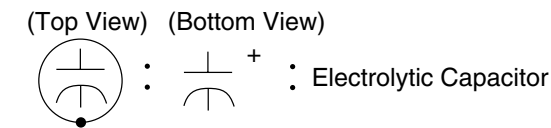

Schematic Diagram Symbols

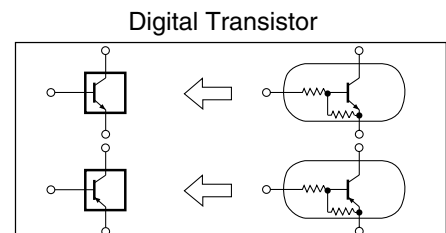

LIST OF CAUTION, NOTES, AND SYMBOLS USED IN THE SCHEMATIC DIAGRAMS ON THE FOLLOWING PAGES:

1. **CAUTION:** FOR CONTINUED PROTECTION AGAINST RISK OF FIRE, REPLACE ONLY WITH SAME TYPE_A,_V FUSE.

ATTENTION: UTILISER UN FUSIBLE DE RECHANGE DE MÊME TYPE DE_A,_V.

2. CAUTION:

Fixed Voltage (or Auto voltage selectable) power supply circuit is used in this unit.

If Main Fuse (F601) is blown, first check to see that all components in the power supply circuit are not defective before you connect the AC plug to the AC power supply. Otherwise it may cause some components in the power supply circuit to fail.

3. Note:

(1) Do not use the part number shown on the drawings for ordering. The correct part number is shown in the parts list, and may be slightly different or amended since the drawings were prepared.

(2) To maintain original function and reliability of repaired units, use only original replacement parts which are listed with their part numbers in the parts list section of the service manual.

4. Wire Connectors

(1) Prefix symbol "CN" means "connector" (can disconnect and reconnect).

(2) Prefix symbol "CL" means "wire-solder holes of the PCB" (wire is soldered directly).

5. **Note:** Mark "●" is a leadless (chip) component.

6. Voltage indications on the schematics are as shown below:

Plug the TV power cord into a standard AC outlet.:

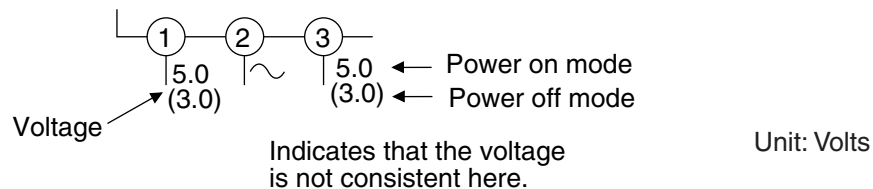

7. How to read converged lines

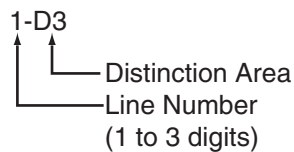

Examples:

1. "1-D3" means that line number "1" goes to area "D3".

2. "1-B1" means that line number "1" goes to area "B1".

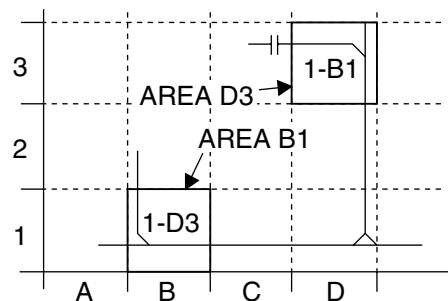

8. Test Point Information

⊕ : Indicates a test point with a jumper wire across a hole in the PCB.

□→ : Used to indicate a test point with a component lead on foil side.

⊘ : Used to indicate a test point with no test pin.

● : Used to indicate a test point with a test pin.

Main 1/3 Schematic Diagram

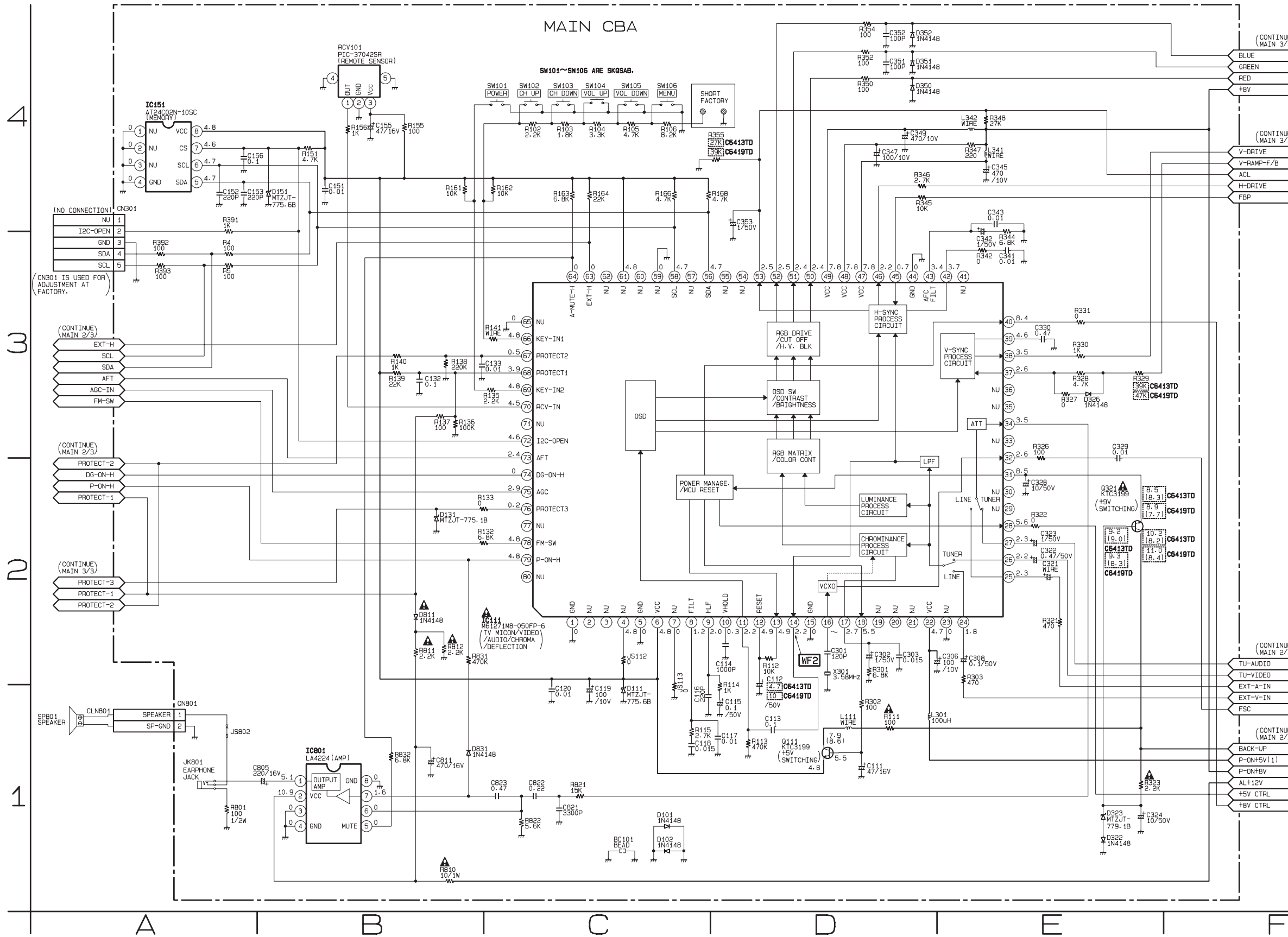

MAIN 1/3

Ref No.	Position
ICS	
IC111	C-2
IC151	A-4
IC801	B-1
TRANSISTORS	
Q111	D-1
Q321	E-2
CONNECTORS	
CN301	A-4
CN801	A-1

A4	B4	C4	D4	E4	F4
A3	B3	C3	D3	E3	F3
A2	B2	C2	D2	E2	F2
A1	B1	C1	D1	E1	F1

VIDEO SIGNAL
AUDIO SIGNAL

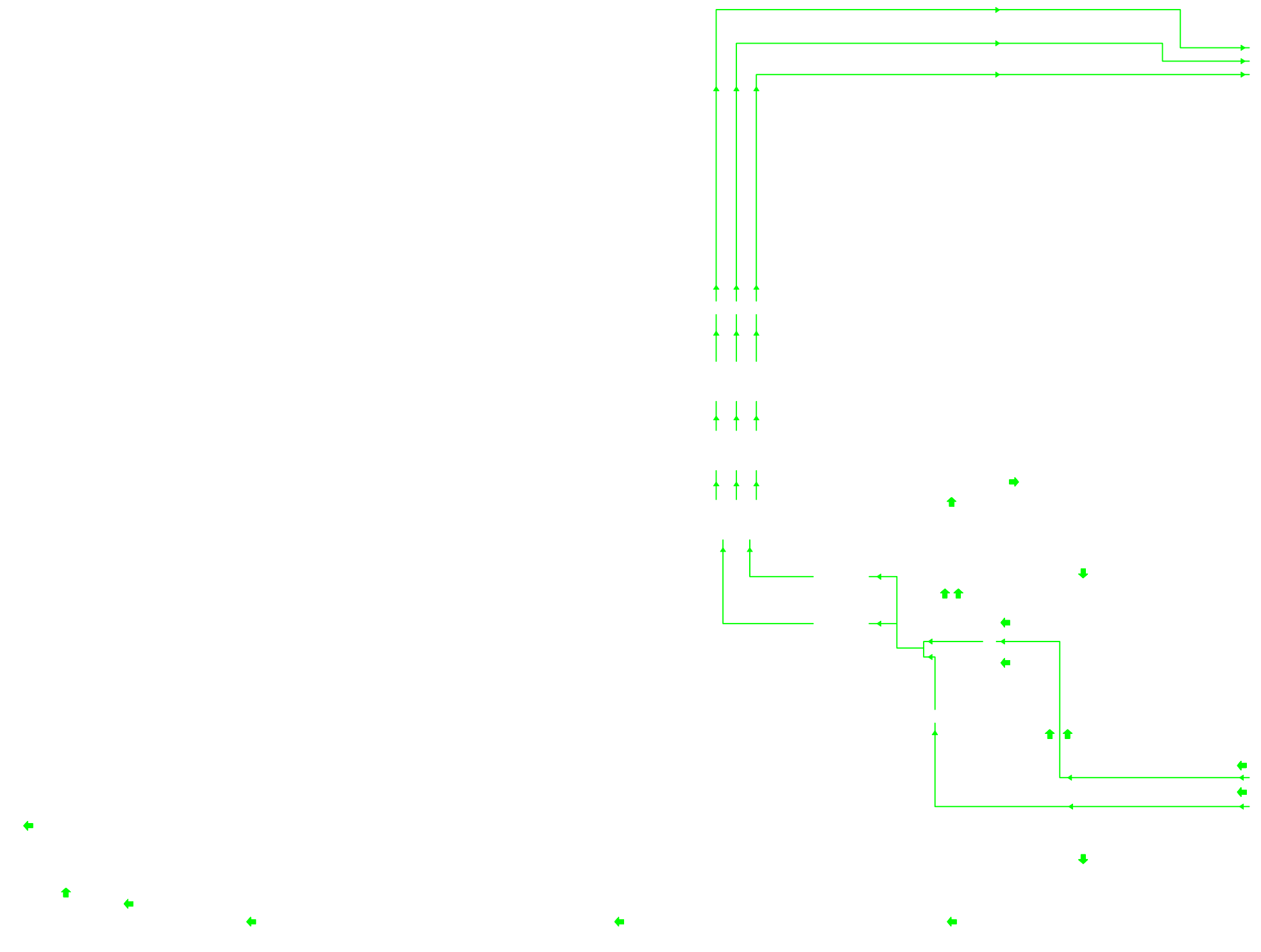

Main 2/3 Schematic Diagram

CAUTION !

Fixed voltage (or Auto voltage selectable) power supply circuit is used in this unit.
If Main Fuse (F601) is blown, check to see that all components in the power supply circuit are not defective before you connect the AC plug to the AC power supply.
Otherwise it may cause some components in the power supply circuit to fail.



CAUTION: FOR CONTINUED PROTECTION AGAINST RISK OF FIRE, REPLACE ONLY WITH SAME TYPE 4A, 125V FUSE.
ATTENTION: UTILISER UN FUSIBLE DE RECHANGE DE MÊME TYPE DE 4A, 125V.

NOTE :
The voltage for parts in hot circuit is measured using hot GND as a common terminal.

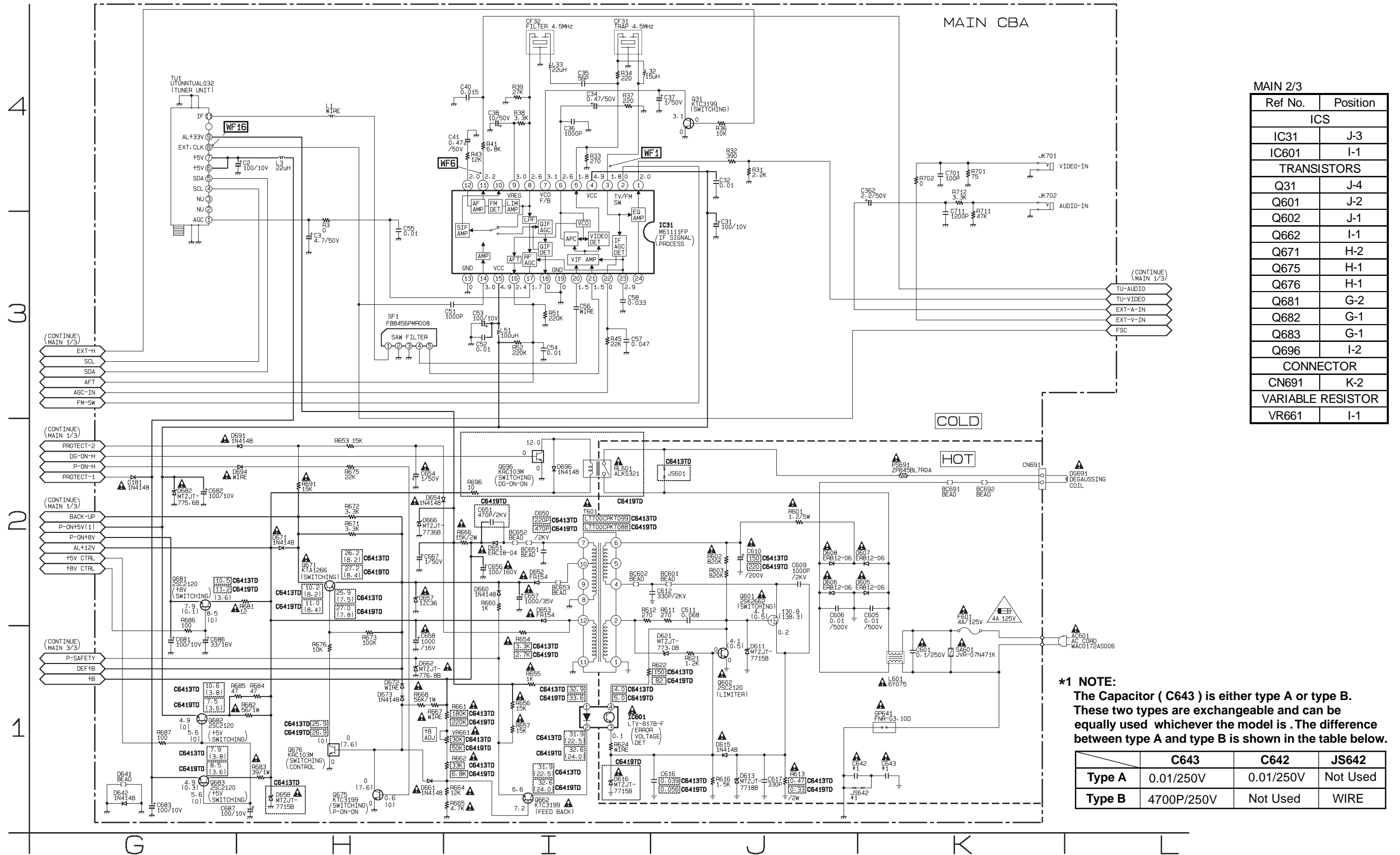

MAIN 2/3

Ref No.	Position
ICS	
IC31	J-3
IC601	I-1
TRANSISTORS	
Q31	J-4
Q601	J-2
Q602	J-1
Q662	I-1
Q671	H-2
Q675	H-1
Q676	H-1
Q681	G-2
Q682	G-1
Q683	G-1
Q696	I-2
CONNECTOR	
CN691	K-2
VARIABLE RESISTOR	
VR661	I-1

***1 NOTE:**
The Capacitor (C643) is either type A or type B. These two types are exchangeable and can be equally used whichever the model is . The difference between type A and type B is shown in the table below.

	C643	C642	JS642
Type A	0.01/250V	0.01/250V	Not Used
Type B	4700P/250V	Not Used	WIRE

G4

H4

I4

J4

K4

L4

G3

H3

I3

J3

K3

L3

G2

H2

I2

J2

K2

L2

G1

H1

I1

J1

K1

L1

--- IF SIGNAL
— VIDEO SIGNAL
← AUDIO SIGNAL

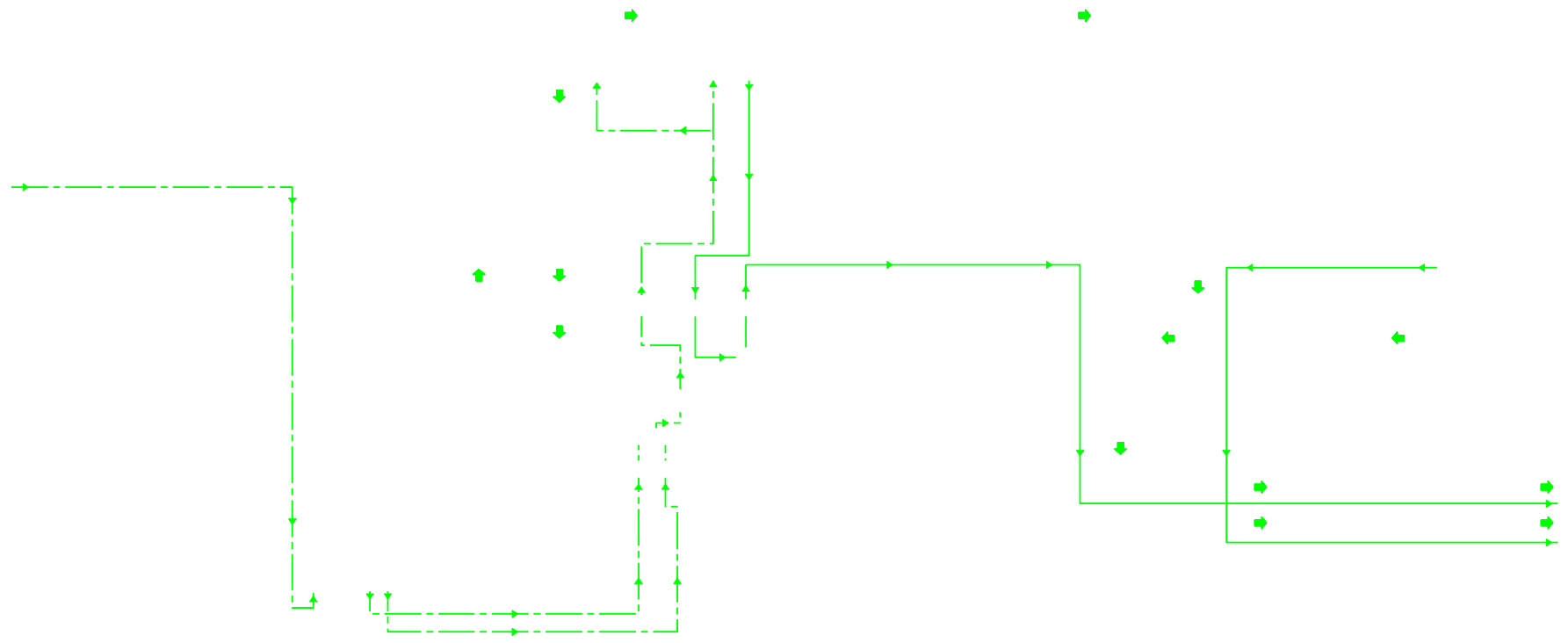

Main 3/3 & CRT Schematic Diagram

MAIN 3/3

Ref No.	Position
IC	
IC551	M-3
TRANSISTORS	
Q571	O-2
Q572	O-2
CONNECTORS	
CN571	N-3
WH301A	P-2
WH501A	P-2
TEST POINTS	
TP300	O-2
TP601	O-2

CRT

Ref No.	Position
TRANSISTORS	
Q501	Q-2
Q502	Q-2
Q503	R-2
CONNECTORS	
CN501	R-2
WH301B	Q-2
WH501B	Q-2

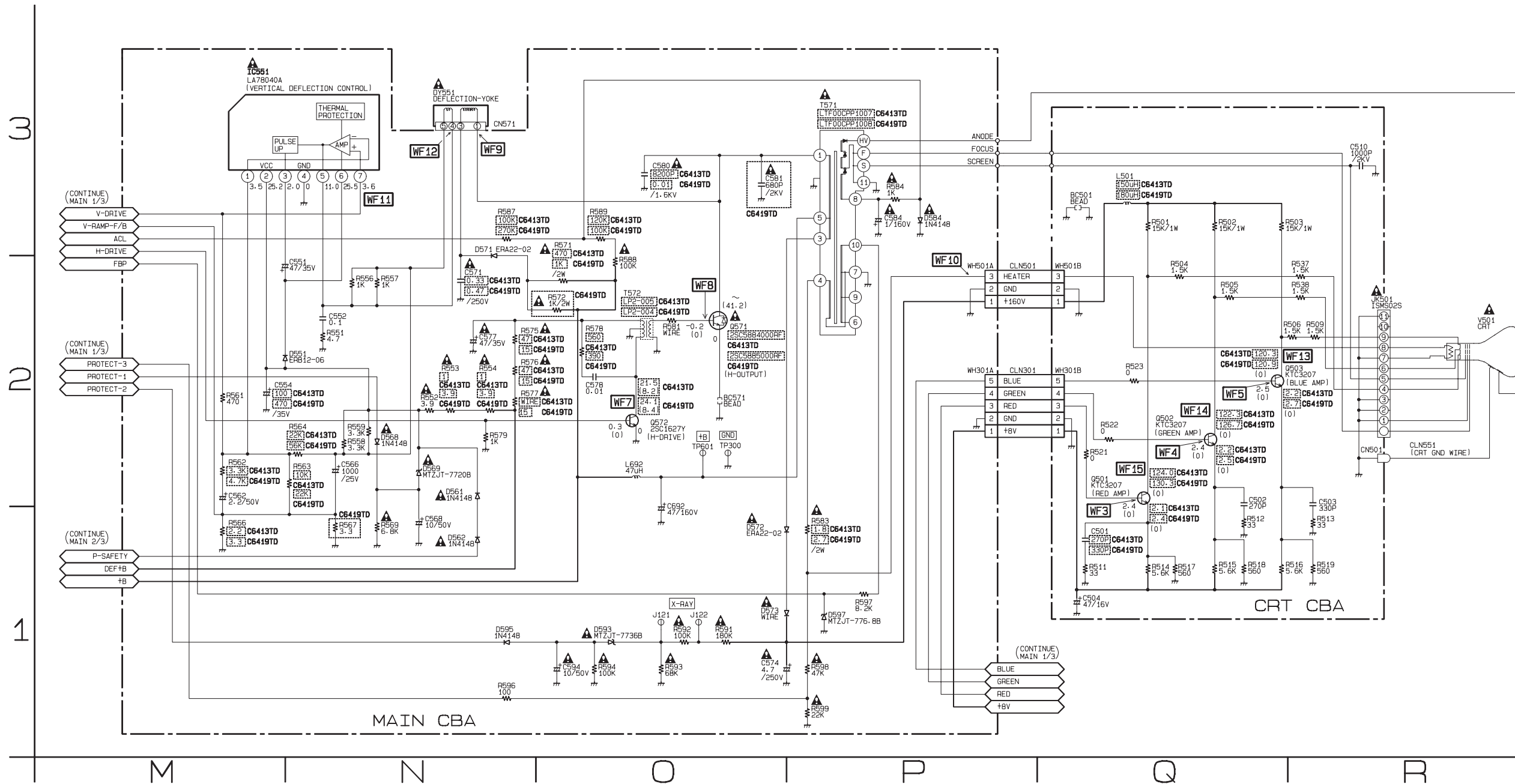

M3	N3	O3	P3	Q3	R3
M2	N2	O2	P2	Q2	R2
M1	N1	O1	P1	Q1	R1

———— VIDEO SIGNAL

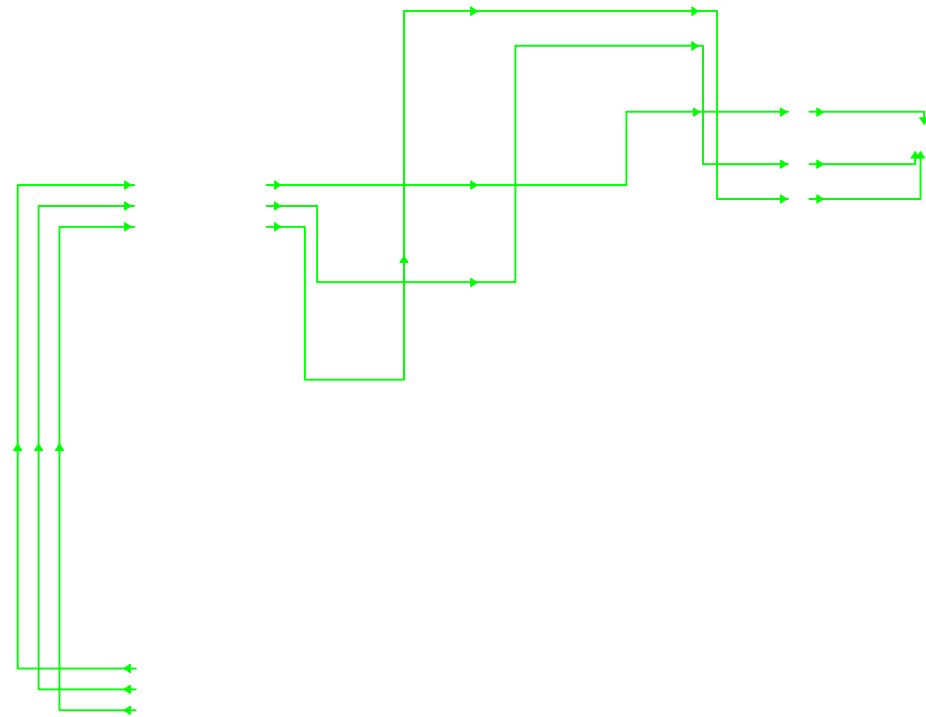

Main CBA Top View

CAUTION !

Fixed voltage (or Auto voltage selectable) power supply circuit is used in this unit.
 If Main Fuse (F601) is blown, check to see that all components in the power supply circuit are not defective before you connect the AC plug to the AC power supply.
 Otherwise it may cause some components in the power supply circuit to fail.



CAUTION: FOR CONTINUED PROTECTION AGAINST RISK OF FIRE, REPLACE ONLY WITH SAME TYPE 4A, 125V FUSE.
ATTENTION: UTILISER UN FUSIBLE DE RECHANGE DE MÊME TYPE DE 4A, 125V.

NOTE:
 The voltage for parts in hot circuit is measured using hot GND as a common terminal.

BECAUSE A HOT CHASSIS GROUND IS PRESENT IN THE POWER SUPPLY CIRCUIT, AN ISOLATION TRANSFORMER MUST BE USED. ALSO, IN ORDER TO HAVE THE ABILITY TO INCREASE THE INPUT SLOWLY, WHEN TROUBLESHOOTING THIS TYPE POWER SUPPLY CIRCUIT, A VARIABLE ISOLATION TRANSFORMER IS REQUIRED.

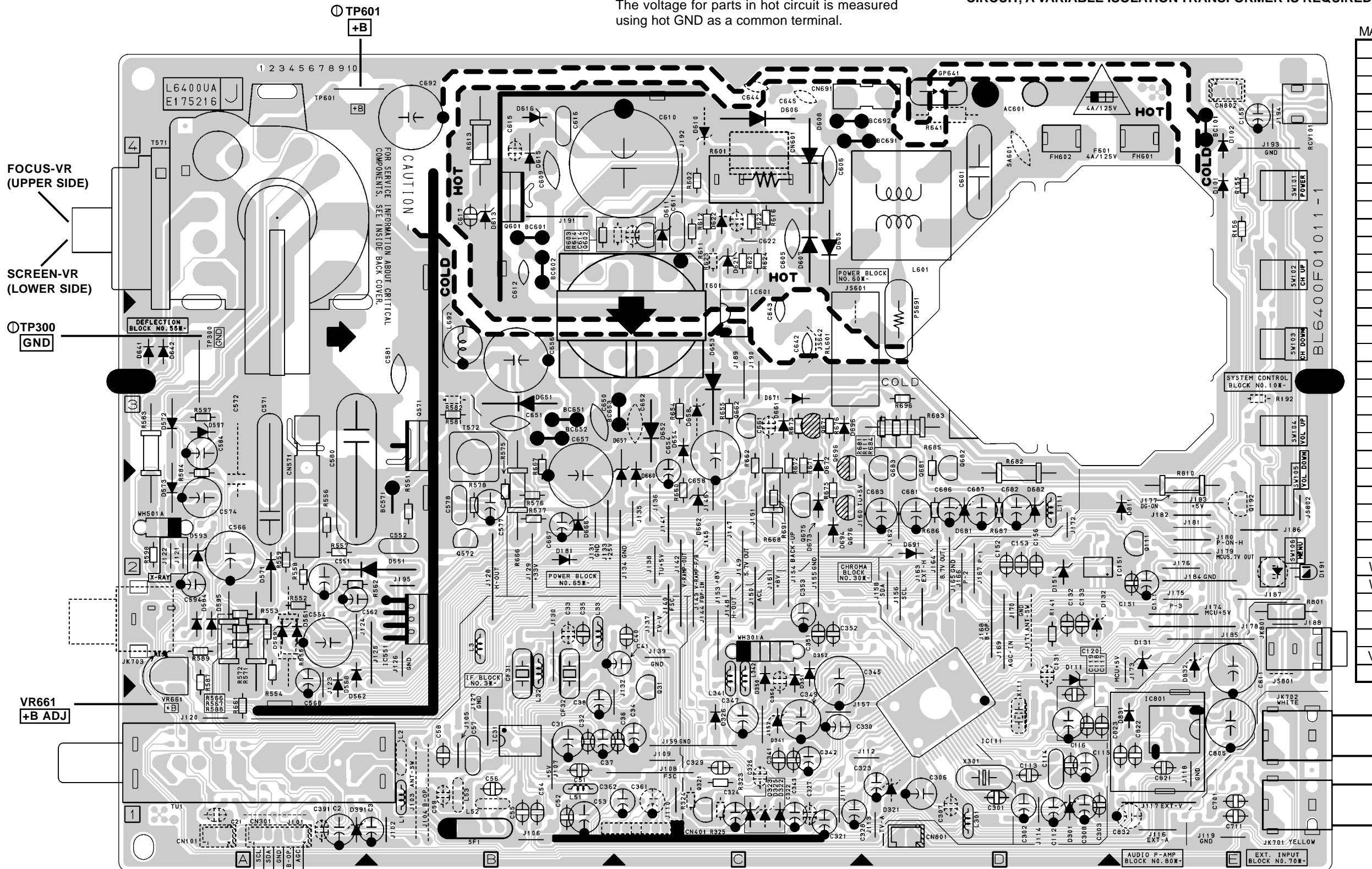

Main CBA Bottom View

CAUTION !

Fixed voltage (or Auto voltage selectable) power supply circuit is used in this unit.
 If Main Fuse (F601) is blown, check to see that all components in the power supply circuit are not defective before you connect the AC plug to the AC power supply.
 Otherwise it may cause some components in the power supply circuit to fail.



CAUTION: FOR CONTINUED PROTECTION AGAINST RISK OF FIRE, REPLACE ONLY WITH SAME TYPE 4A, 125V FUSE.
ATTENTION: UTILISER UN FUSIBLE DE RECHANGE DE MÊME TYPE DE 4A, 125V.

NOTE :
 The voltage for parts in hot circuit is measured using hot GND as a common terminal.

BECAUSE A HOT CHASSIS GROUND IS PRESENT IN THE POWER SUPPLY CIRCUIT, AN ISOLATION TRANSFORMER MUST BE USED. ALSO, IN ORDER TO HAVE THE ABILITY TO INCREASE THE INPUT SLOWLY, WHEN TROUBLESHOOTING THIS TYPE POWER SUPPLY CIRCUIT, A VARIABLE ISOLATION TRANSFORMER IS REQUIRED.

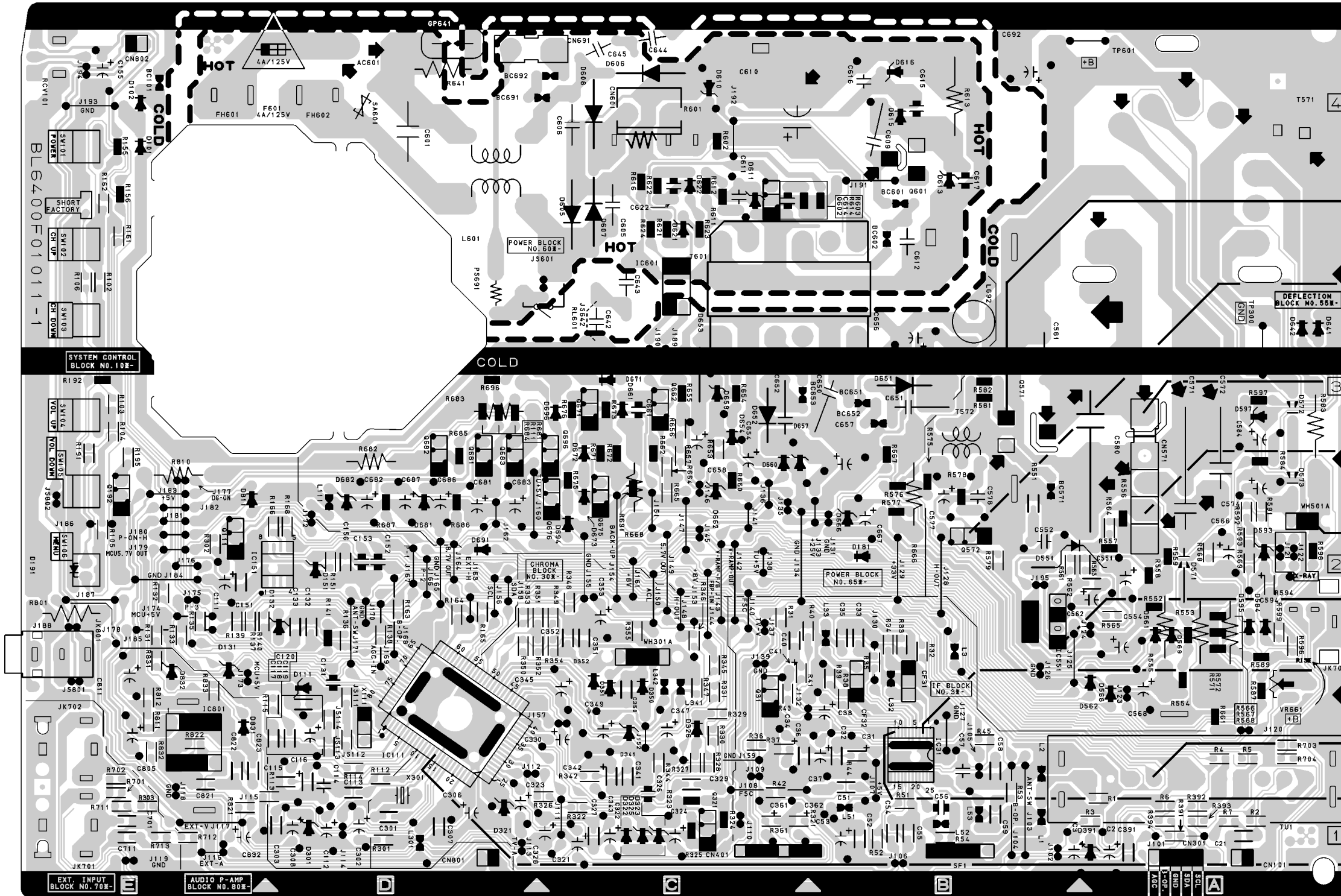

- WF8**
- Q571
- Base
- WF7**
- Q572
- Collector
- WF9**
- PIN 1
- OF CN571
- WF12**
- PIN 4
- OF CN571
- WF10**
- PIN 3
- OF WH501A
- WF11**
- PIN 7
- OF IC551
- WF1**
- PIN 3
- OF IC31
- WF16**
- PIN 8
- OF TU1
- WF6**
- PIN 11
- OF IC31
- WF2**
- PIN 14
- OF IC111

CRT CBA Top View

CRT CBA Bottom View

CRT CBA	
Ref No.	Position
TRANSISTORS	
Q501	B-2
Q502	B-2
Q503	B-2
CONNECTORS	
CN501	A-1
WH301B	B-1
WH501B	B-1

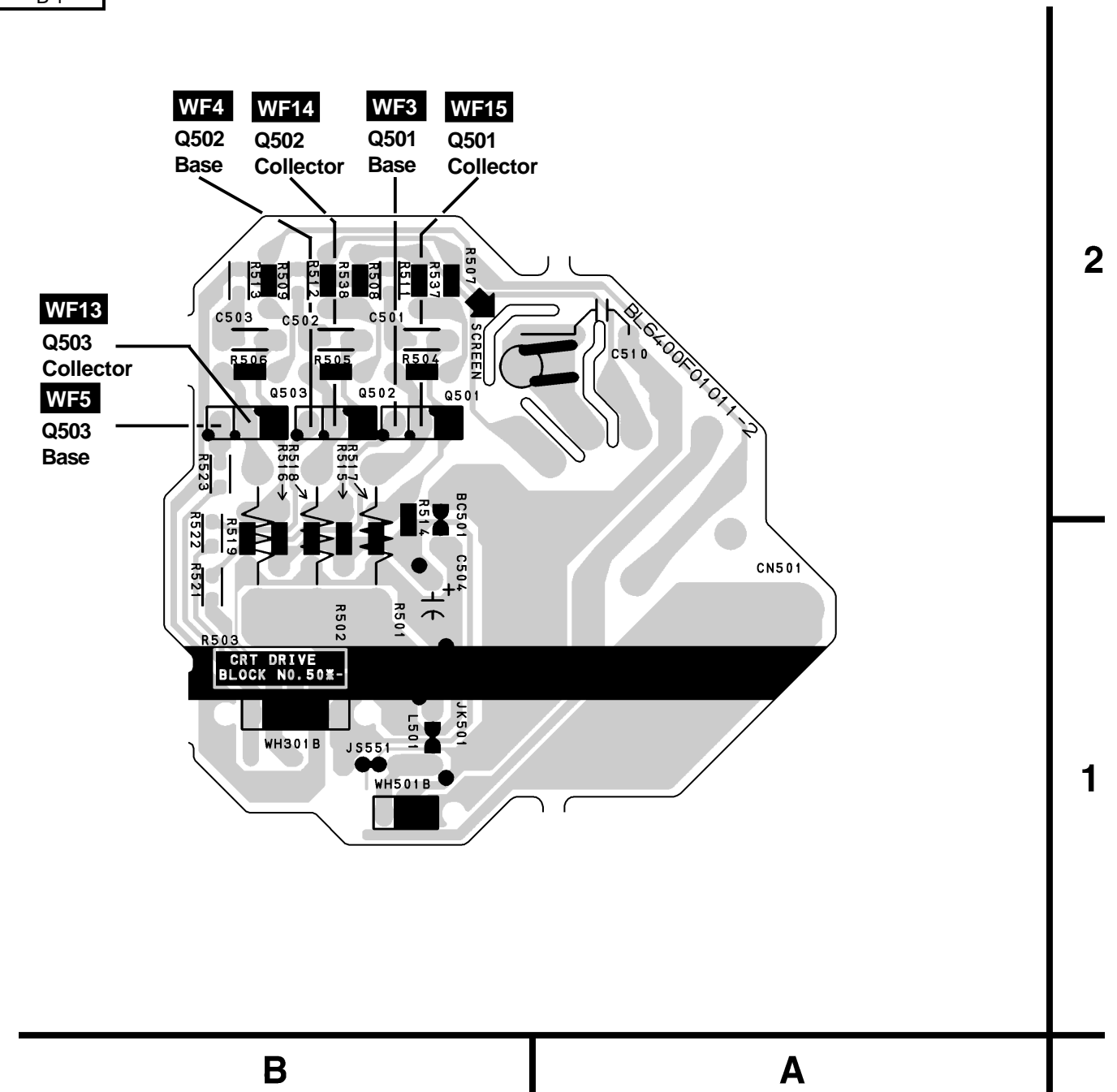
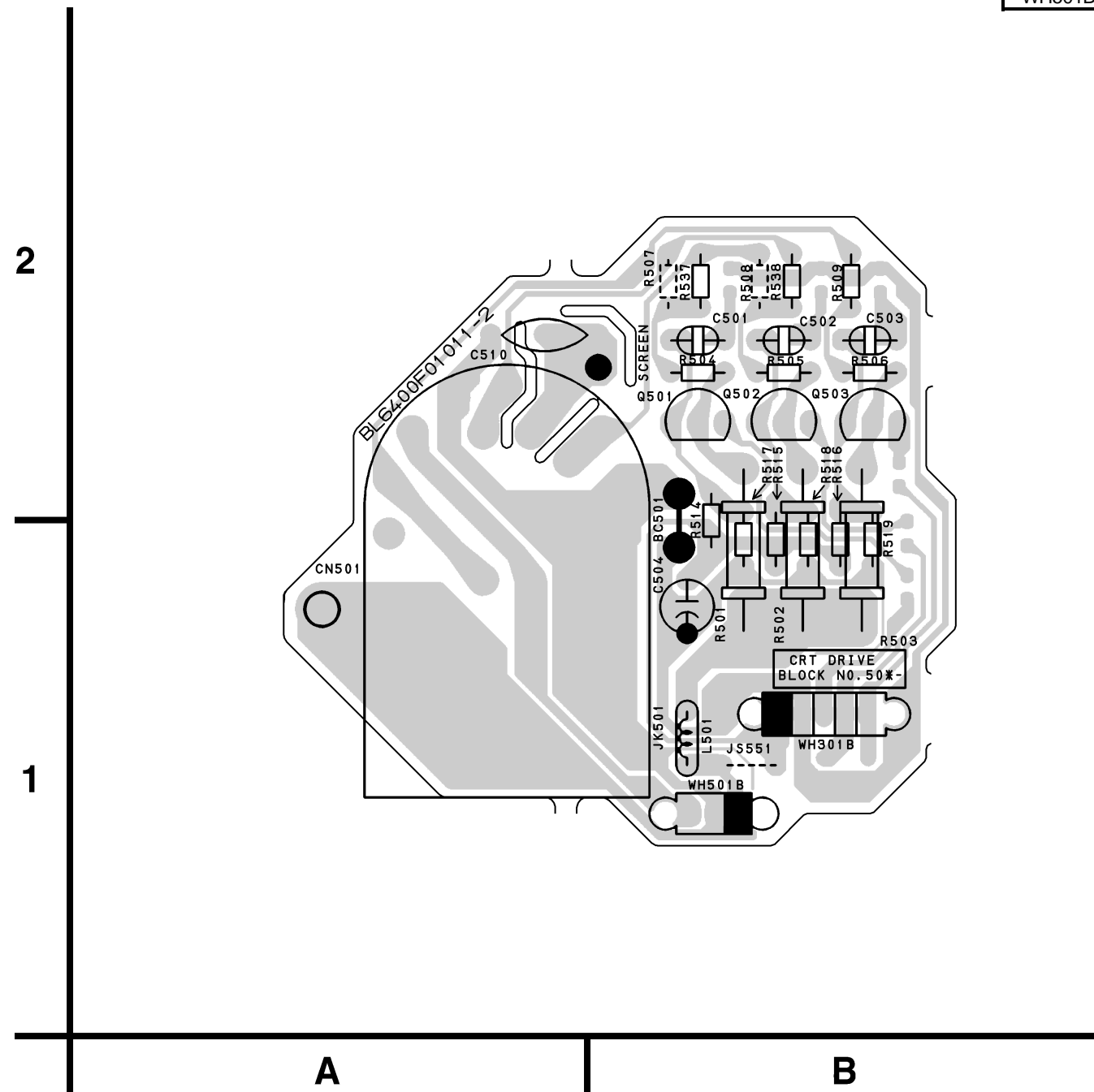

WAVEFORMS

WF1 ~ WF16 = Waveforms to be observed at Waveform check points. (Shown in Schematic Diagram.)

Input: NTSC Color Bar Signal (with 1kHz Audio Signal)
INITIAL POSITION: Unplug unit from AC outlet for at least 5 minutes. reconnect to AC outlet and then turn power on.
 (Brightness---Center Color---Center Tint --- Center Contrast---Approx 70%)

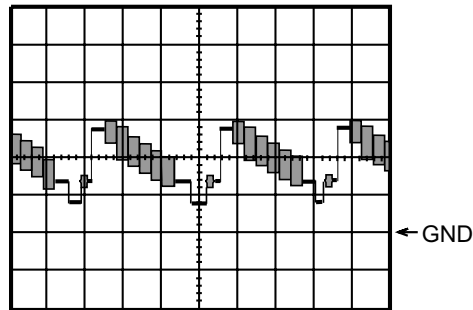

WF1 1DIV: 0.5V 20 μ sec
IC 31 Pin 3

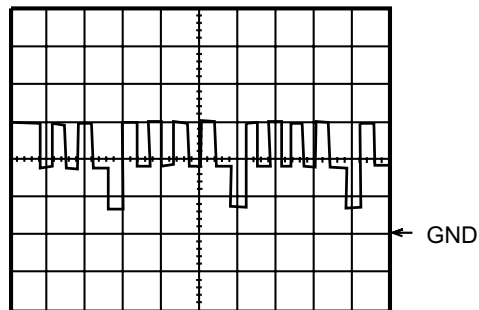

WF5 1DIV: 2V 20 μ sec
Q 503 Base

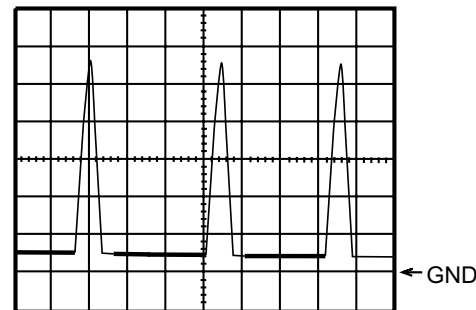

WF9 1DIV: 200V 20 μ sec
CN 571 Pin 1

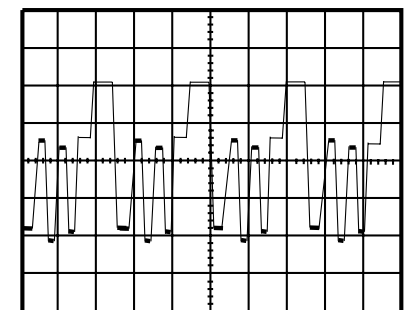

WF13 1DIV: 20V 20 μ sec
Q503 Collector

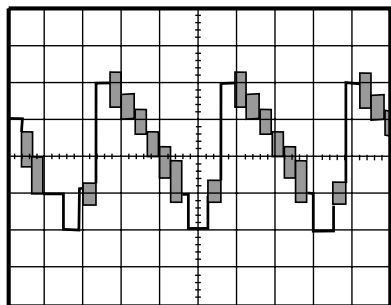

WF2 1DIV: 0.5V 20 μ sec
IC 111 Pin 14

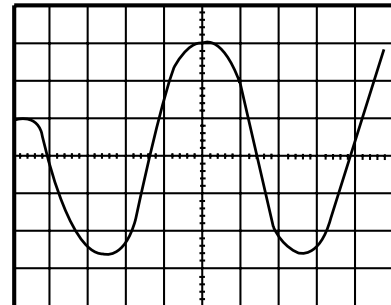

WF6 1DIV: 0.2V 20msec
IC 31 Pin 11

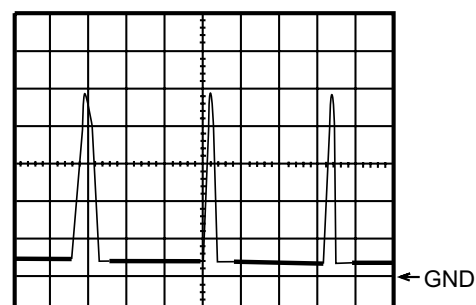

WF10 1DIV: 5V 20 μ sec
CN501A Pin 3

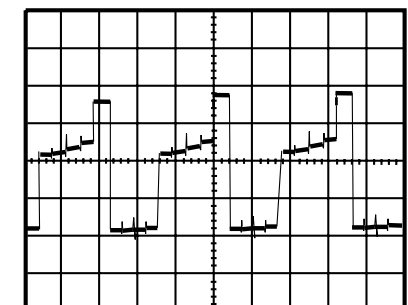

WF14 1DIV: 20V 20 μ sec
Q 502 Collector

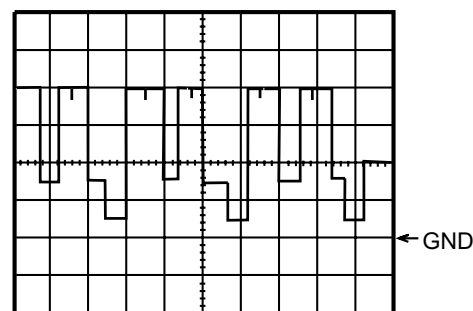

WF3 1DIV: 2V 20 μ sec
Q501 Base

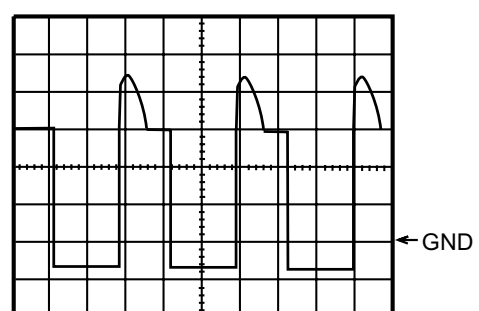

WF7 1DIV: 10V 20 μ sec
Q 572 Collector

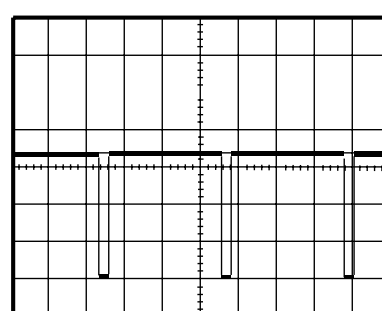

WF11 1DIV: 2V 5msec
IC 551 Pin 7

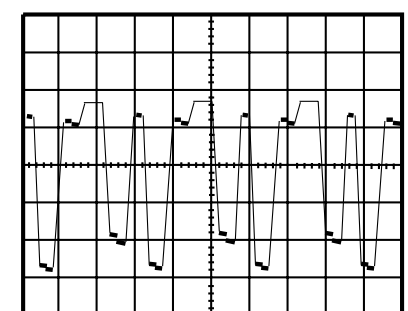

WF15 1DIV: 20V 20 μ sec
Q 501 Collector

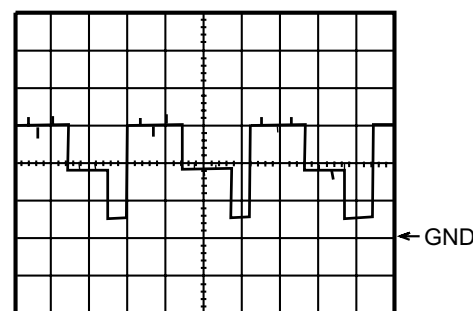

WF4 1DIV: 2V 20 μ sec
Q 502 Base

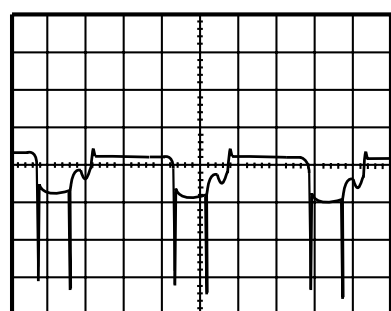

WF8 1DIV: 5V 20 μ sec
Q 571 Base

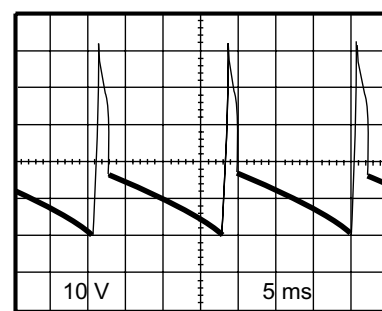

WF12 1DIV: 10V 5msec
CN 571 Pin 4

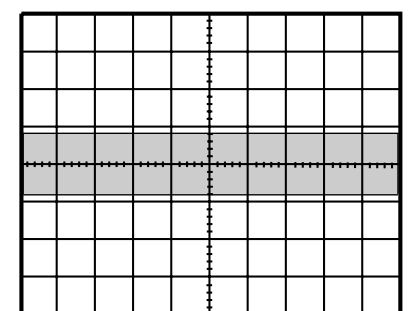

WF16 1DIV: 0.2V 20 μ sec
TU 1 Pin 8

WIRING DIAGRAM

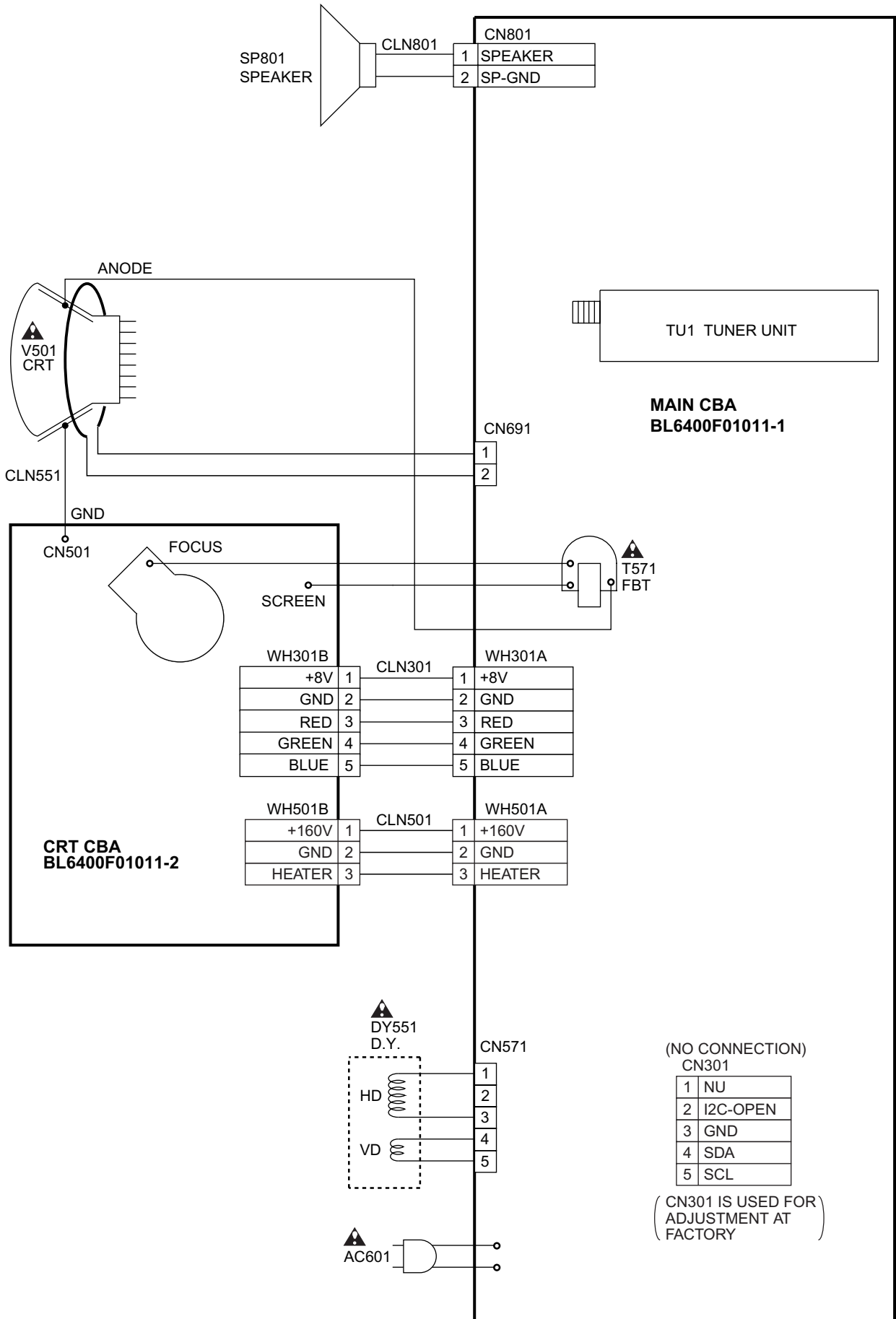

IC PIN FUNCTIONS

IC111(TV Micro Computer)

Pin No.	Signal Name	Function
1	GND	GND
2	N.U.	Not Used
3	N.U.	Not Used
4	N.U.	Not Used
5	GND	GND
6	VCC	AL+5V
7	N.U.	Not Used
8	FILT	FILT
9	HLF	Filter for CCD
10	VHOLD	VHOLD
11	CVIN	Input for Video Signal
12	RESET	RESET
13	MCU RESET OUT	RESET Signal Output
14	Y-SW OUT	Composite Signal Output
15	GND	GND
16	3.58 X'TAL	3.58MHz Crystal
17	C-APC	CHROMINANCE APC
18	MCU 5.7REG OUT	Micro controller Control Voltage Output
19	N.U.	Not Used
20	N.U.	Not Used
21	N.U.	Not Used
22	VCC	VCC
23	N.U.	(GND)
24	CVBS IN2	Composite Signal Input 2
25	AUDIO IN2	Audio Signal Input 2
26	CVBS IN1	Composite Signal Input 1
27	AUDIO IN1	Audio Signal Input 1
28	5.7V REG OUT	5.7V Output
29	N.U.	Not Used
30	N.U.	Not Used
31	V REG VCC	DC 8.7V Input
32	FSC OUT	Clock Output 3.58MHz
33	N.U.	Not Used
34	AUDIO ATT OUT	Audio Signal Output

Pin No.	Signal Name	Function
35	N.U.	Not Used
36	N.U.	Not Used
37	V RAMP F/B	V Ramp Feed Back
38	V RAMP OUT	Vertical Output
39	V RAMP CAP	V Ramp OSC Capacitor
40	8.7 VREG OUT	DC 8.7V Output
41	N.U.	Not Used
42	H VCO F/B	H Vco Feed Back
43	AFC FILT	Horizontal AFC Filter
44	GND	GND
45	FBP IN	Flyback Pulse Input
46	H-OUT	H Pulse Output
47	VCC	Vcc
48	VCC	Vcc
49	VCC	Vcc
50	R OUT	Red Output
51	G OUT	Green Output
52	B OUT	Blue Output
53	ACL	IB-Input
54	N.U.	Not Used
55	N.U.	Not Used
56	SDA	I2C-BUS Controller Interface (Data)
57	N.U.	Not Used
58	SCL	I2C-BUS Controller Interface (Clock)
59	N.U.	(GND)
60	N.U.	Not Used
61	N.U.	(+5V)
62	N.U.	Not Used
63	EXT-H	EXT-H
64	A-MUTE-H	Audio Mute
65	N.U.	Not Used
66	KEY-IN 1	Key Input 1 (Main)
67	PROTECT 2	Power Supply Protection
68	PROTECT 1	Power Supply Protection
69	KEY-IN 2	Key Input 2 (Main)
70	RCV-IN	Input For Remote Control

Pin No.	Signal Name	Function
71	N.U.	Not Used
72	I2C OPEN	White Balance Adjustment Judgement
73	AFT	AFT Voltage Input
74	N.U.	Not Used
75	AGC	AGC Voltage Input
76	PROTECT 3	Power Supply Protection
77	N.U.	Not Used
78	FM-SW	Switching IF IC VCO
79	P-ON-H	Output for P-ON-H
80	N.U.	Not Used

EXPLODED VIEWS

Cabinet [C6413TD]

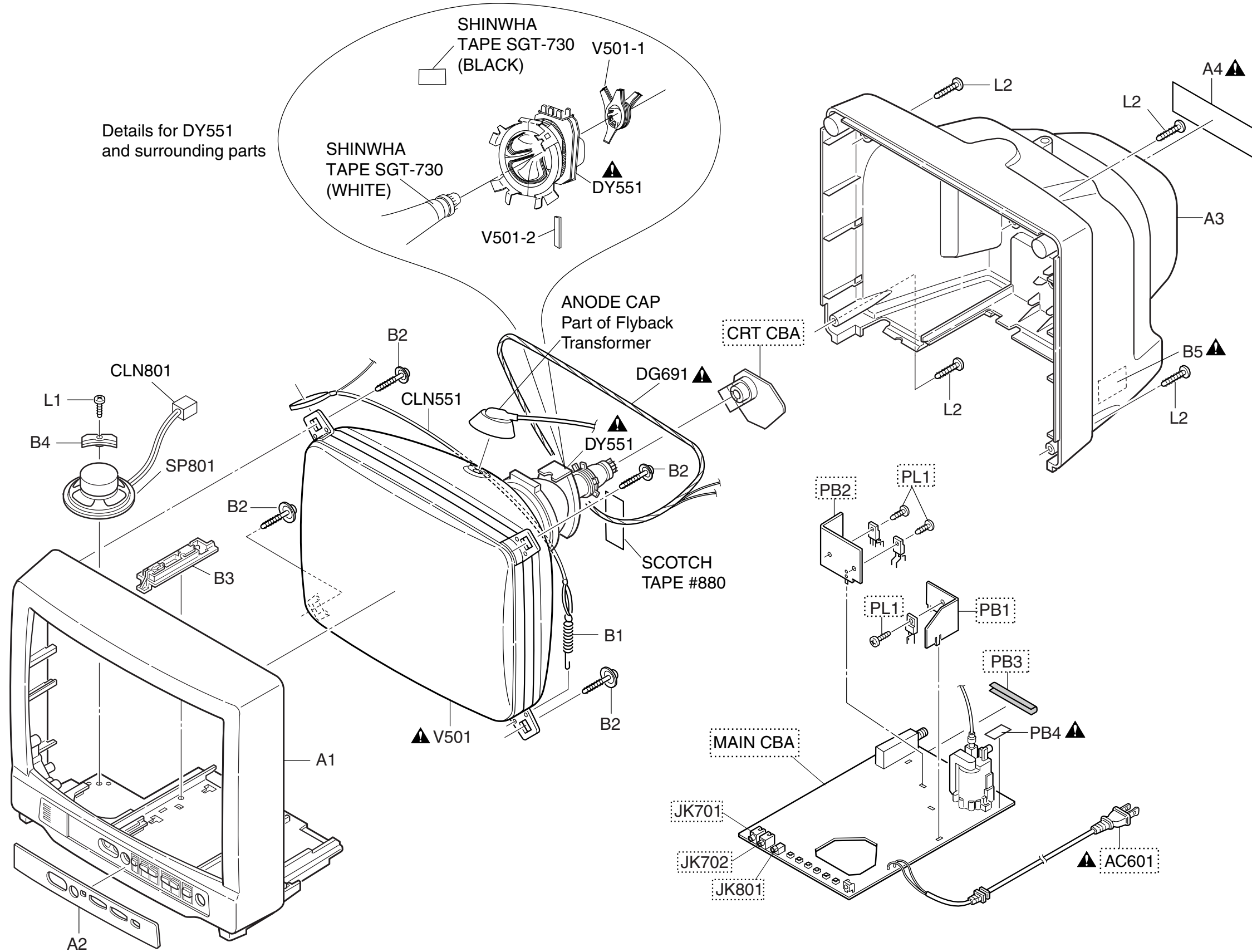

Cabinet [C6419TD]

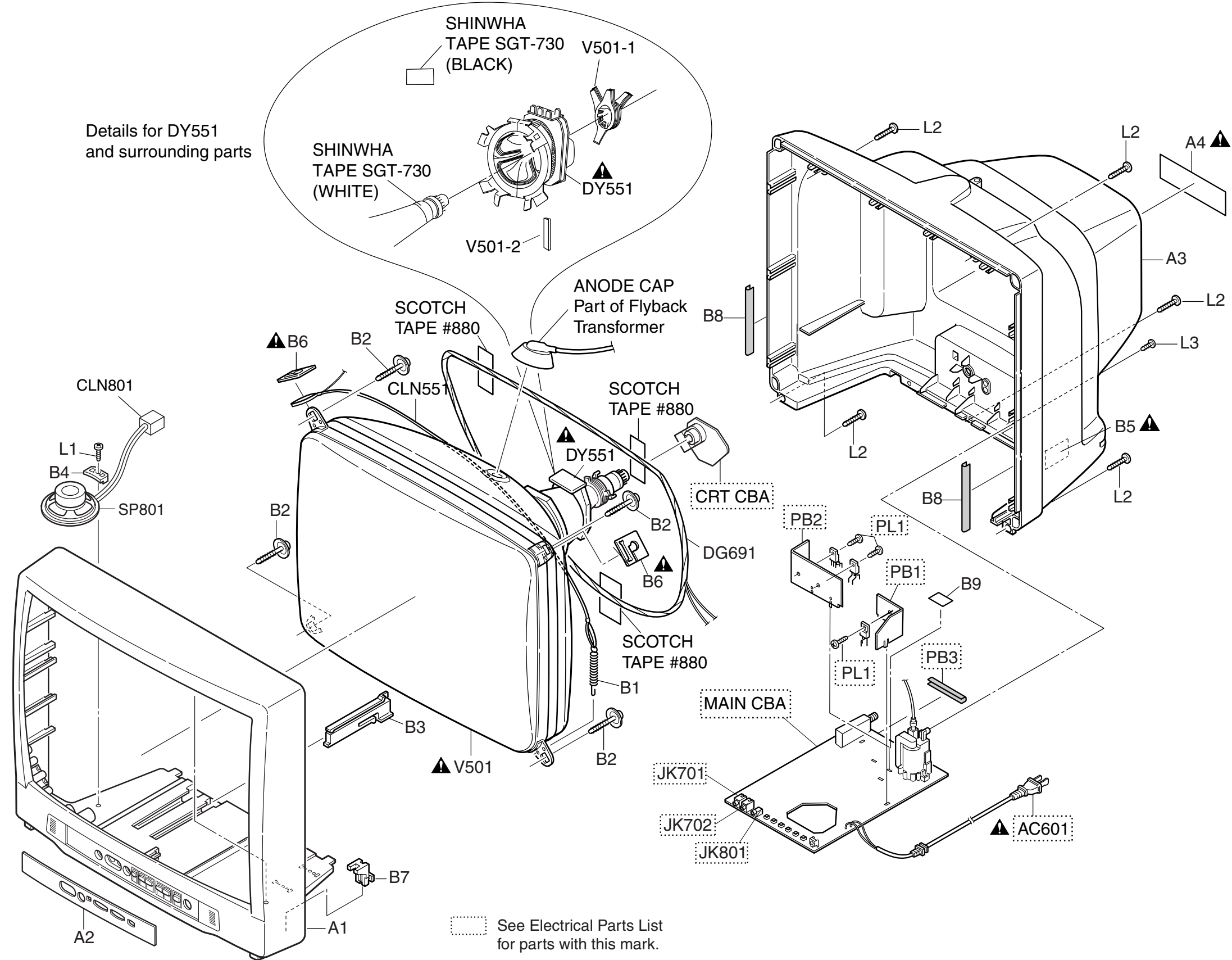

Packing [C6413TD]

Some Ref. Numbers are not in sequence.

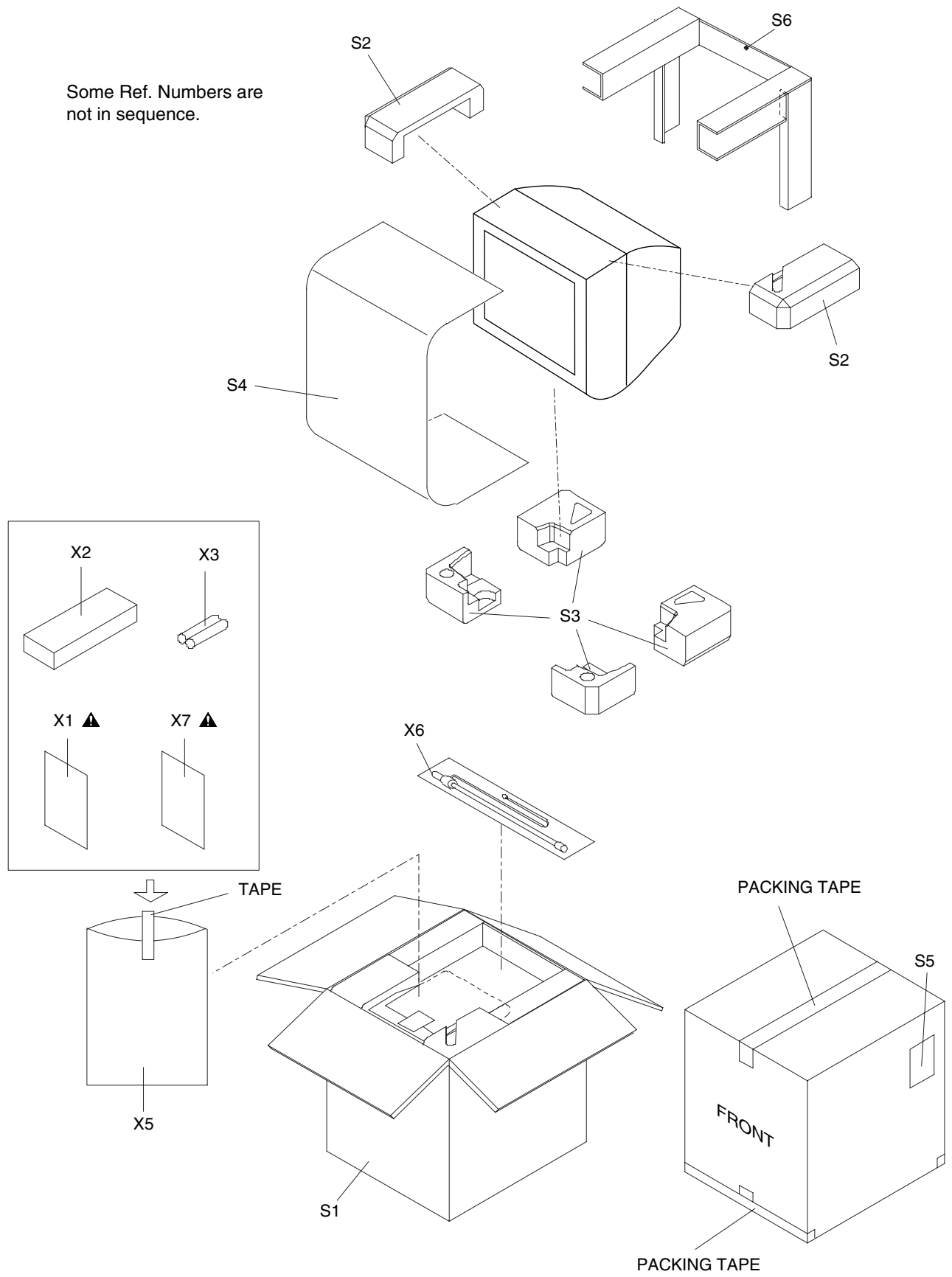

Packing [C6419TD]

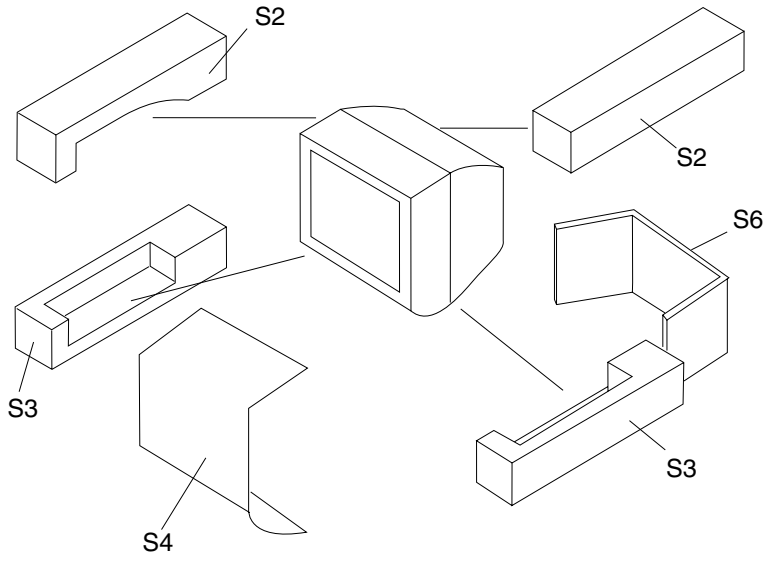

Some Ref. Numbers are not in sequence.

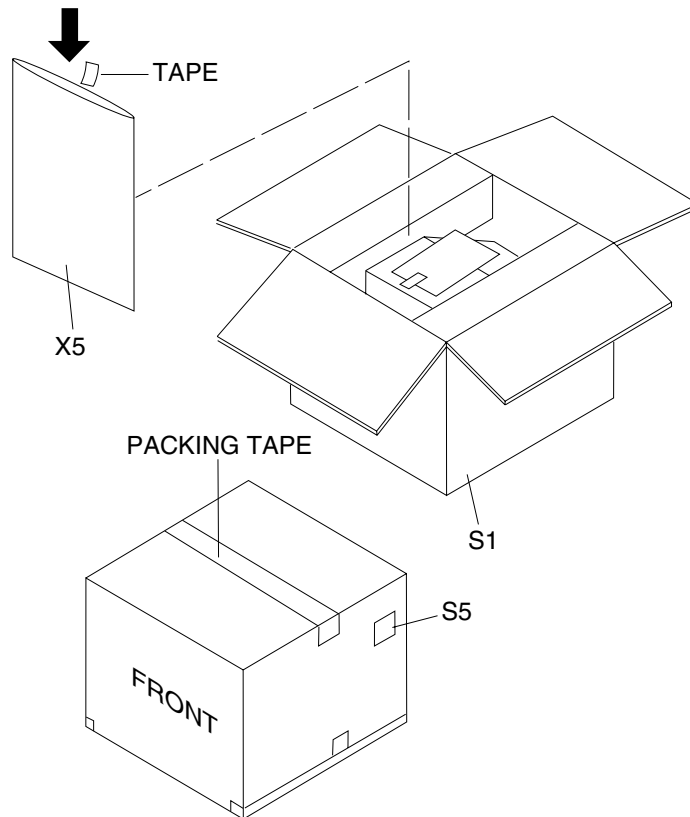
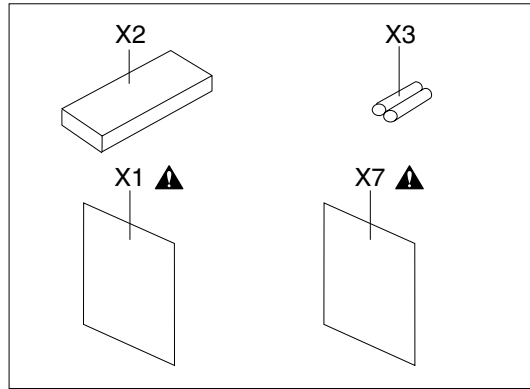

MECHANICAL PARTS LIST

PRODUCT SAFETY NOTE: Products marked with a **▲** have special characteristics important to safety. Before replacing any of these components, read carefully the product safety notice in this service manual. Don't degrade the safety of the product through improper servicing.

NOTE:

Parts that are not assigned part numbers (-----) are not available.

C6413TD

Ref. No.	Description	Part No.
A1	FRONT CABINET L1300UA	0EM000485
A2	CONTROL PLATE L6301UB	0EM301757
A3	REAR CABINET L6300UA or	0EM101240
	REAR CABINET L6300UA or	0EM101248
	REAR CABINET L6305UF	0EM000678
A4▲	RATING LABEL L6303CD	-----
B1	TENSION SPRING B0080B0:EM40808	26WH006
B2	CRT MOUNTING SCREW B0030U1:K42419	8A00083
B3	PCB HOLDER L1300UA	0EM301412
B4	SPEAKER HOLDER L1300UA	0EM406030
B5▲	CRITICAL PARTS WARNING LABEL B8007C3:EM41210	24LH199
CLN551	CRT GND WIRE CRT GND	WX1L7720-001
CLN801	WIRE ASSEMBLY	WX1L9200-001
DG691▲	DEGAUSSING COIL F-017 or	LLBH00ZTM017
▲	DEGAUSSING COIL AVDG013 or	LLBH00ZWR017
▲	DEGAUSSING COIL or	LLBH00ZTZ017
▲	DEGAUSSING COIL LLBH00ZTM022	LLBH00ZTM022
L1	SCREW, P-TIGHT 3X12 BIND HEAD+	GBMP3120
L2	SCREW, P-TIGHT 4X18 BIND HEAD +	GBMP4180
SP801	SPEAKER S08F02B or	DSD0808XQ010
	SPEAKER J-F097-C5	DSD0808DCP01
PB4▲	CHASSIS NO. LABEL L6300UA	0EM407512
PACKING		
S1	CARTON L6303CD	0EM407812
S2	STYRFOAM TOP ASSEMBLY L6000UA	0EM406803
S3	STYRFOAM BOTTOM ASSEMBLY L6000UA	0EM406802
S4	SET SHEET L6000UA:700X1200	0EM407141
S5	HOLD PAD L6000UA	0EM201556
S6	SERIAL NO. LABEL L6303CD	0EM407811
ACCESSORIES		
X1▲	OWNER'S MANUAL(E)/(S) L6403CD:ENGLISH/ SPANISH	0EMN02076
X2	REMOTE CONTROL 130/ERC001/N0108UD or	N0108UD
	REMOTE CONTROL 130/ERC001/N0132UD	N0132UD
X3	DRY BATTERY R6P UM3 or	XB0M451GH001
	DRY BATTERY R6P/2S or	XB0M451T0001
	DRY BATTERY (SUNRISE) R6SSE/2S or	XB0M451MS002
	DRY BATTERY R6P(AR)2PX or	XB0M451HU002
	DRY BATTERY R6P(AR)2P X ICI	XB0M451HU003
X5	POLYETHYLENE BAG F8626B5	Z325350
X6	ROD ANTENNA L7720UA:NTSC W/COO	0EMN00673
X6▲	ROD ANTENNA T5000UA	0EMN01599
X7▲	QUICK SETUP GUIDE L1004CE	0EMN01726

Ref. No.	Description	Part No.
Note:		
1. V501 (CRT) HAS COUPLE OF SUBSTITUTIONAL PARTS AND EACH PARTS ALSO HAS MATCHING COMBINATION WITH DY551. PLEASE SEE TABLE 1 FOR DETAILS OF MATCHING COMBINATION.		
2. DY551 (DEFLECTION YOKE) HAS MATCHING COMBINATION WITH V501. PLEASE SEE TABLE 1 FOR DETAILS OF MATCHING COMBINATION.		
CRT TYPE A		
DY551▲	DEFLECTION YOKE KDY3GDA82X or	LLBY00ZMS011
▲	DEFLECTION YOKE LLBY00ZSY005	LLBY00ZSY005
V501▲	CRT A34AGT13X	TCRT190CP036
V501-1	C.PMAGNET JH225-FN-00	XM04000BV003
V501-2	WEDGE FT-00110W or	XV10000T4001
	WEDGE DB25SR	XV10000D9001
CRT TYPE B		
DY551▲	DEFLECTION YOKE LLBY00ZSY002 or	LLBY00ZSY002
▲	DEFLECTION YOKE CDY-M1456S or	LLBY00ZQS008
▲	DEFLECTION YOKE KDY3GC734X or	LLBY00ZMS006
▲	DEFLECTION YOKE KDY3GCE83X or	LLBY00ZMS027
▲	DEFLECTION YOKE DSE1493FU(S)	LLBY00ZSM008
V501▲	CRT A34KQW42X	TCRT190SM013
V501-1	C.PMAGNET JH225-014	XM04000BV009
V501-2	WEDGE FT-00110W or	XV10000T4001
	WEDGE DB25SR	XV10000D9001
CRT TYPE C		
DY551▲	DEFLECTION YOKE KDY3GD591X or	LLBY00ZMS005
▲	DEFLECTION YOKE CDY-M1422F	LLBY00ZQS001
V501▲	CRT A34JLL90X(W)	TCRT190QS015
V501-1	C.PMAGNET JH225-FN-00	XM04000BV003
V501-2	WEDGE FT-00110W or	XV10000T4001
	WEDGE DB25SR	XV10000D9001
CRT TYPE D		
DY551▲	DEFLECTION YOKE LLBY00ZSY003 or	LLBY00ZSY003
▲	DEFLECTION YOKE KDY3GD592X or	LLBY00ZMS004
▲	DEFLECTION YOKE CDY-M1455F	LLBY00ZQS007
V501▲	CRT A34LRQ90X(VW)	TCRT190P7003
V501-1	C.PMAGNET JH225-FN-00	XM04000BV003
V501-2	WEDGE FT-00110W or	XV10000T4001
	WEDGE DB25SR	XV10000D9001
CRT TYPE E		
DY551▲	DEFLECTION YOKE LLBY00ZSY002 or	LLBY00ZSY002
▲	DEFLECTION YOKE KDY3GC587X or	LLBY00ZMS003
▲	DEFLECTION YOKE CDY-M1456S or	LLBY00ZQS008
▲	DEFLECTION YOKE KDY3GCE83X	LLBY00ZMS027
V501▲	CRT A34KPU02XX	TCRT190GS016
V501-1	C.PMAGNET JH225-FN-00	XM04000BV003
V501-2	WEDGE FT-00110W or	XV10000T4001
	WEDGE DB25SR	XV10000D9001
CRT TYPE F		
DY551▲	DEFLECTION YOKE KDY3GCB05X or	LLBY00ZMS014
▲	DEFLECTION YOKE ST14PWR01	LLBY00ZSAM01
V501▲	CRT A34LEX10X	TCRT190SAM01
V501-1	C.PMAGNET JH225-FN-00	XM04000BV003
V501-2	WEDGE FT-00110W or	XV10000T4001
	WEDGE DB25SR	XV10000D9001
CRT TYPE G		
DY551▲	DEFLECTION YOKE LLBY00ZSY002 or	LLBY00ZSY002
▲	DEFLECTION YOKE KDY3GCB82X or	LLBY00ZMS018
▲	DEFLECTION YOKE KDY3GCE83X	LLBY00ZMS027

Ref. No.	Description	Part No.
V501▲	GRT A34JQQ093X	TCRT190MS010
V501-1	C.PMAGNET JH225-FN-00	XM04000BV003
V501-2	WEDGE FT-00110W or WEDGE DB25SR	XV10000T4001 XV10000D9001
CRT TYPE H		
V501▲	CRT A34JXV70X	TCRT190THA02
V501-2	WEDGE FT-00110W or WEDGE DB25SR	XV10000T4001 XV10000D9001

C6419TD

Ref. No.	Description	Part No.
A1	FRONT CABINET L1400UA	0EM000479
A2	CONTROL PLATE L6101UB	0EM301600
A3	REAR CABINET L6400UA or REAR CABINET L6405UF	0EM000683 0EM000679
A4▲	RATING LABEL L6403CD	-----
B1	TENSION SPRING B0080B0:EM40808	26VH006
B2	CRT MOUNTING SCREW B0030U1:K42419	8A00083
B3	PCB HOLDER L1400UA	0EM301429
B4	SPEAKER HOLDER L1400UA	0EM406026
B5▲	CRITICAL PARTS WARNING LABEL B8007C3:EM41210	24LH199
B6▲	DEGAUSS HOLDER L9800UA	0EM404845
B7	AC CORD HOLDER L1400UA	0EM406104
B8	CLOTH L9800UA:95X15XT:0.5	0EM405041
B9	CLOTH(10X30XT1.0) L9814UQ	0EM405137
CLN551	CRT GND WIRE CRT GND	WX1L7820-003
CLN801	WIRE ASSEMBLY SPEAKER WIRE(220MM)	WX1L7950-001
DG691▲	DEGAUSSING COIL AVDG014 or ▲ DEGAUSSING COIL F-003	LLBH00ZWR003 LLBH00ZTM003
L1	SCREW, P-TIGHT 3X12 BIND HEAD+	GBMP3120
L2	SCREW, P-TIGHT 4X18 BIND HEAD +	GBMP4180
L3	SCREW TAPPING M4X14	DBU14140
SP801	SPEAKER S08F02B or SPEAKER J-F097-C5	DSD0808XQ010 DSD0808DCP01
PACKING		
S1	CARTON L6403CD	0EM407802
S2	STYRFOAM TOP ASSEMBLY L9814UQ	0EM405094
S3	STYRFOAM BOTTOM ASSEMBLY L6100UA	0EM406813
S4	SET SHEET L1400UA:1000X1500	0EM406680
S5	HOLD PAD L6100UA	0EM406812
S6	SERIAL NO. LABEL L6403CD	0EM407801
ACCESSORIES		
X1▲	OWNER'S MANUAL(E)/(S) L6403CD:ENGLISH/ SPANISH	0EMN02076
X2	REMOTE CONTROL 130/ERC001/N0108UD or REMOTE CONTROL 130/ERC001/N0132UD	N0108UD N0132UD
X3	DRY BATTERY R6P UM3 or DRY BATTERY R6P/2S or DRY BATTERY(SUNRISE) R6SSE/2S or DRY BATTERY R6P(AR)2PX or DRY BATTERY R6P(AR)2P X ICI	XB0M451GH001 XB0M451T0001 XB0M451MS002 XB0M451HU002 XB0M451HU003
X5	POLYETHYLENE BAG F8626B5	Z325350
X7▲	QUICK SETUP GUIDE L1004CE	0EMN01726
Note: 1. V501 (CRT) HAS COUPLE OF SUBSTITUTIONAL PARTS AND EACH PARTS ALSO HAS MATCHING COMBINATION WITH DY551. PLEASE SEE TABLE 1 FOR DETAILS OF MATCHING COMBINATION. 2. DY551 (DEFLECTION YOKE) HAS MATCHING COMBINATION WITH V501. PLEASE SEE TABLE 1 FOR DETAILS OF MATCHING COMBINATION.		
CRT TYPE A		

Ref. No.	Description	Part No.
DY551▲	DEFLECTION YOKE KDY3MDA84X or ▲ DEFLECTION YOKE LLYB00ZSY006 or ▲ DEFLECTION YOKE CDY-M2019F	LLBY00ZMS013 LLBY00ZSY006 LLBY00ZQS004
V501▲	CRT A48JLL90X or ▲ CRT A48JLL90X(K)	TCRT190QS009 TCRT190QS019
V501-1	C.PMAGNET JH225-014 or CPM E-225-F01	XM04000BV009 XM04000ETC01
V501-2	WEDGE FT-001 10W or WEDGE DB25SR	XV10000T4001 XV10000D9001
CRT TYPE B		
DY551▲	DEFLECTION YOKE KDY3MCB20X or ▲ DEFLECTION YOKE 330P510A37	LLBY00ZMS016 LLBY00ZTHA01
V501▲	CRT A48LGS30X	TCRT190THA01
V501-1	C.PMAGNET JH225-014 or CPM E-225-F01	XM04000BV009 XM04000ETC01
V501-2	WEDGE FT-001 10W or WEDGE DB25SR	XV10000T4001 XV10000D9001
CRT TYPE C		
DY551▲	DEFLECTION YOKE DSE-1922FU(T) or ▲ DEFLECTION YOKE TMY0301F or ▲ DEFLECTION YOKE CDY-M2023F or ▲ DEFLECTION YOKE LLYB00ZSY007	LLBY00ZSM007 LLBY00ZMS017 LLBY00ZQS005 LLBY00ZSY007
V501▲	CRT A48LRH93X(W)D or ▲ CRT A48LRH93X(W)	TCRT190PTD01 TCRT190P7002
V501-1	C.PMAGNET JH225-014 or CPM E-225-F01	XM04000BV009 XM04000ETC01
V501-2	WEDGE FT-001 10W or WEDGE DB25SR	XV10000T4001 XV10000D9001
CRT TYPE D		
DY551▲	DEFLECTION YOKE LLYB00ZSY008	LLBY00ZSY008
V501▲	CRT A48LVL095X	TCRT190MS011
V501-1	C.PMAGNET JH225-014 or CPM E-225-F01	XM04000BV009 XM04000ETC01
V501-2	WEDGE FT-001 10W or WEDGE DB25SR	XV10000T4001 XV10000D9001
CRT TYPE E		
V501▲	CRT A48AKH13X01 K	TCRT190CP043
CRT TYPE F		
DY551▲	DEFLECTION YOKE KDY3MDD74X	LLBY00ZMS024
V501▲	CRT A48AKH13X	TCRT190CP044
V501-1	C.PMAGNET JH225-014 or CPM E-225-F01	XM04000BV009 XM04000ETC01
V501-2	WEDGE FT-001 10W or WEDGE DB25SR	XV10000T4001 XV10000D9001

Table 1 (V501 and DY551 Combination)

Note 1: Purity and Convergence Adjustments must be performed following CRT replacement. Refer to Electrical Adjustment Instructions.

Note 2: Please confirm CRT Type No. on the CRT Warning Label which is located on the CRT. Then See the Table 1 for V501 and DY551 combination chart. Please refer this CRT, Deflection Yoke combination chart for parts order.

C6413TD

V501: CRT Type No.	V501: CRT Part No.	DY551: Deflection Yoke Part No.
CRT A34AGT13X	TCRT190CP036	LLBY00ZMS011
		LLBY00ZSY005
CRT A34KQW42X	TCRT190SM013	LLBY00ZSY002
		LLBY00ZQS008
		LLBY00ZMS006
		LLBY00ZMS027
		LLBY00ZSM008
		LLBY00ZMS005
CRT A34JLL90X(W)	TCRT190QS015	LLBY00ZQS001
		LLBY00ZSY003
CRT 34LRQ90X(VW)	TCRT190P7003	LLBY00ZMS004
		LLBY00ZQS007
		LLBY00ZSY002
CRT A34KPU02XX	TCRT190GS016	LLBY00ZMS003
		LLBY00ZQS008
		LLBY00ZMS027
		LLBY00ZMS014
CRT A34LEX10X	TCRT190SAM01	LLBY00ZSAM01
		LLBY00ZSY002
CRT A34JQQ093X	TCRT190MS010	LLBY00ZMS018
		LLBY00ZMS027

CRT A34JXV70X	TCRT190THA02	-----

CRT Warning Label Location

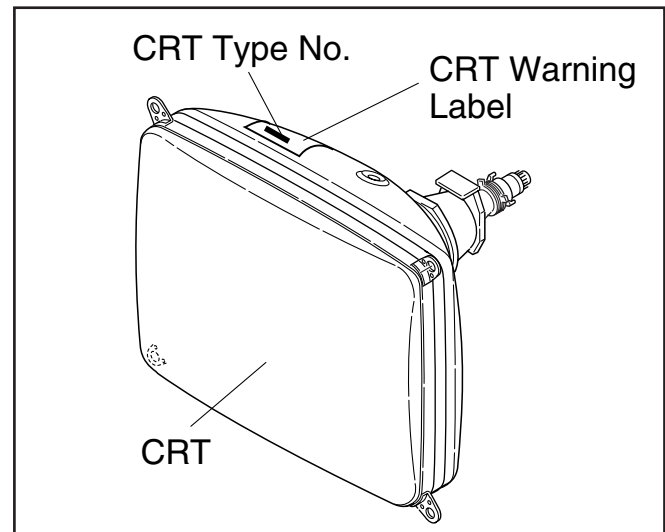

C6419TD

V501: CRT Type No.	V501: CRT Part No.	DY551: Deflection Yoke Part No.
CRT A48JLL90X	TCRT190QS009	LLBY00ZMS013
		LLBY00ZSY006
		LLBY00ZQS004
CRT A48JLL90X(K)	TCRT190QS019	LLBY00ZMS013
		LLBY00ZSY006
		LLBY00ZQS004
CRT A48LGS30X	TCRT190THA01	LLBY00ZMS016
		LLBY00ZTHA01
CRT A48LRH93X(W)D	TCRT190PTD01	LLBY00ZSM007
		LLBY00ZMS017
		LLBY00ZQS005
		LLBY00ZSY007
CRT A48LRH93X(W)	TCRT190P7002	LLBY00ZSM007
		LLBY00ZMS017
		LLBY00ZQS005
		LLBY00ZSY007
CRT A48LVL095X	TCRT190MS011	LLBY00ZSY008
CRT A48AEY13X01 K	TCRT190CP043	-----
CRT A48AKH13X	TCRT190CP044	LLBY00ZMS024

ELECTRICAL PARTS LIST

PRODUCT SAFETY NOTE: Products marked with a  have special characteristics important to safety. Before replacing any of these components, read carefully the product safety notice in this service manual. Don't degrade the safety of the product through improper servicing.

NOTES:

- Parts that are not assigned part numbers (-----) are not available.
- Tolerance of Capacitors and Resistors are noted with the following symbols.

C.....±0.25% D.....±0.5% F.....±1%
 G.....±2% J.....±5% K.....±10%
 M.....±20% N.....±30% Z.....+80/-20%

Comparison Chart of Models and Marks

Model	Mark
C6413TD	A
C6419TD	B

MMA CBA

Ref. No.	Mark	Description	Part No.
	A	MMA-384 CBA	0ESA04985
	B	MMA-383 CBA	0ESA04923
		Consists of the following	
		MAIN CBA	-----
		CRT CBA	-----

MAIN CBA

Ref. No.	Mark	Description	Part No.
		MAIN CBA Consists of the following	-----
CAPACITORS			
C2		ELECTROLYTIC CAP. 100µF/10V M or	CE1AMASTL101
		ELECTROLYTIC CAP. 100µF/10V M	CE1AMASDL101
C3		ELECTROLYTIC CAP. 4.7µF/50V M or	CE1JMASTL4R7
		ELECTROLYTIC CAP. 4.7µF/50V M	CE1JMASDL4R7
C31		ELECTROLYTIC CAP. 100µF/10V M or	CE1AMASTL101
		ELECTROLYTIC CAP. 100µF/10V M	CE1AMASDL101
C32		CHIP CERAMIC CAP. B K 0.01µF/50V	CHD1JKB0B103
C34		ELECTROLYTIC CAP. 0.47µF/50V M or	CE1JMASTL4R7
		ELECTROLYTIC CAP. 0.47µF/50V M	CE1JMASDL4R7
C35		CHIP CERAMIC CAP. CH J 56pF/50V	CHD1JJBCH560
C36		CHIP CERAMIC CAP. B K 1000pF/50V	CHD1JKB0B102
C37		ELECTROLYTIC CAP. 1µF/50V M or	CE1JMASTL1R0
		ELECTROLYTIC CAP. 1µF/50V M or	CE1JMASDL1R0
		ELECTROLYTIC CAP. 1µF/50V M	CE1JMASDL010
C38		ELECTROLYTIC CAP. 10µF/50V M or	CE1JMASTL100
		ELECTROLYTIC CAP. 10µF/50V M	CE1JMASDL100

Ref. No.	Mark	Description	Part No.
C40		CHIP CERAMIC CAP. B K 0.015µF/50V	CHD1JKB0B153
C41		ELECTROLYTIC CAP. 0.47µF/50V M or	CE1JMASTL4R7
		ELECTROLYTIC CAP. 0.47µF/50V M	CE1JMASDL4R7
C51		CHIP CERAMIC CAP. B K 1000pF/50V	CHD1JKB0B102
C52		CHIP CERAMIC CAP. B K 0.01µF/50V	CHD1JKB0B103
C53		ELECTROLYTIC CAP. 100µF/10V M or	CE1AMASTL101
		ELECTROLYTIC CAP. 100µF/10V M	CE1AMASDL101
C54		CHIP CERAMIC CAP. B K 0.01µF/50V	CHD1JKB0B103
C55		CHIP CERAMIC CAP. B K 0.01µF/50V	CHD1JKB0B103
C56		PCB JUMPER D0.6-P5.0	JW5.0T
C57		FILM CAP.(P) 0.047µF/50V J or	CMA1JJS00473
		FILM CAP.(P) 0.047µF/50V J	CA1J473MS029
C58		FILM CAP.(P) 0.033µF/50V J or	CMA1JJS00333
		FILM CAP.(P) 0.033µF/50V J	CA1J333MS029
C111		ELECTROLYTIC CAP. 47µF/16V M or	CE1CMASL470
		ELECTROLYTIC CAP. 47µF/16V M	CE1CMASDL470
C112	A	ELECTROLYTIC CAP. 4.7µF/50V M or	CE1JMASTL4R7
	A	ELECTROLYTIC CAP. 4.7µF/50V M	CE1JMASDL4R7
C112	B	ELECTROLYTIC CAP. 10µF/50V M or	CE1JMASTL100
	B	ELECTROLYTIC CAP. 10µF/50V M	CE1JMASDL100
C113		CHIP CERAMIC CAP. F Z 0.1µF/25V	CHD1EZB0F104
C114		FILM CAP.(P) 0.001µF/50V J or	CMA1JJS00102
		FILM CAP.(P) 0.001µF/50V J	CA1J102MS029
C115		ELECTROLYTIC CAP. 0.1µF/50V M or	CE1JMASTL1R0
		ELECTROLYTIC CAP. 0.1µF/50V M or	CE1JMASDL1R0
		ELECTROLYTIC CAP. 0.1µF/50V M	CE1JMASDL0R1
C116		CHIP CERAMIC CAP. CH J 220pF/50V	CHD1JJBCH221
C117		CHIP CERAMIC CAP. B K 0.01µF/50V	CHD1JKB0B103
C118		CHIP CERAMIC CAP. B K 0.015µF/50V	CHD1JKB0B153
C119		ELECTROLYTIC CAP. 100µF/10V M or	CE1AMASTL101
		ELECTROLYTIC CAP. 100µF/10V M	CE1AMASDL101
C120		CHIP CERAMIC CAP. B K 0.01µF/50V	CHD1JKB0B103
C132		CHIP CERAMIC CAP. F Z 0.1µF/25V	CHD1EZB0F104
C133		CHIP CERAMIC CAP. B K 0.01µF/50V	CHD1JKB0B103
C151		CHIP CERAMIC CAP. B K 0.01µF/50V	CHD1JKB0B103
C152		CERAMIC CAP.(AX) B K 220pF/50V	CCA1JKT0B221
C153		CERAMIC CAP.(AX) B K 220pF/50V	CCA1JKT0B221
C155		ELECTROLYTIC CAP. 47µF/16V M or	CE1CMASL470
		ELECTROLYTIC CAP. 47µF/16V M	CE1CMASDL470
C156		CHIP CERAMIC CAP. F Z 0.1µF/25V	CHD1EZB0F104
C301		CHIP CERAMIC CAP. CH J 120pF/50V	CHD1JJBCH121
C302		ELECTROLYTIC CAP. 1µF/50V M or	CE1JMASTL1R0
		ELECTROLYTIC CAP. 1µF/50V M or	CE1JMASDL1R0
		ELECTROLYTIC CAP. 1µF/50V M	CE1JMASDL010
C303		CHIP CERAMIC CAP. B K 0.015µF/50V	CHD1JKB0B153
C306		ELECTROLYTIC CAP. 100µF/10V M or	CE1AMASTL101
		ELECTROLYTIC CAP. 100µF/10V M	CE1AMASDL101
C308		ELECTROLYTIC CAP. 0.1µF/50V M or	CE1JMASTL1R0
		ELECTROLYTIC CAP. 0.1µF/50V M or	CE1JMASDL1R0
		ELECTROLYTIC CAP. 0.1µF/50V M	CE1JMASDL0R1
C321		PCB JUMPER D0.6-P5.0	JW5.0T
C322		ELECTROLYTIC CAP. 0.47µF/50V M or	CE1JMASTL4R7
		ELECTROLYTIC CAP. 0.47µF/50V M	CE1JMASDL4R7
C323		ELECTROLYTIC CAP. 1µF/50V M or	CE1JMASTL1R0
		ELECTROLYTIC CAP. 1µF/50V M or	CE1JMASDL1R0
		ELECTROLYTIC CAP. 1µF/50V M	CE1JMASDL010
C324		ELECTROLYTIC CAP. 10µF/50V M or	CE1JMASTL100

Ref. No.	Mark	Description	Part No.
		ELECTROLYTIC CAP. 10μF/50V M	CE1JMASDL100
C328		ELECTROLYTIC CAP. 10μF/50V M or	CE1JMASTL100
		ELECTROLYTIC CAP. 10μF/50V M	CE1JMASDL100
C329		CHIP CERAMIC CAP. B K 0.01μF/50V	CHD1JKB0B103
C330		FILM CAP. 0.47μF/50V J or	122Z317S
		TF CAP. 0.47μF/50V J	CT1J474MS045
C341		CHIP CERAMIC CAP. B K 0.01μF/50V	CHD1JKB0B103
C342		ELECTROLYTIC CAP. 1μF/50V M or	CE1JMASTL1R0
		ELECTROLYTIC CAP. 1μF/50V M or	CE1JMASDL1R0
		ELECTROLYTIC CAP. 1μF/50V M	CE1JMASDL010
C343		CHIP CERAMIC CAP. B K 0.01μF/50V	CHD1JKB0B103
C345		ELECTROLYTIC CAP. 470μF/10V M or	CE1AMASTL471
		ELECTROLYTIC CAP. 470μF/10V M	CE1AMASDL471
C347		ELECTROLYTIC CAP. 100μF/10V M or	CE1AMASTL101
		ELECTROLYTIC CAP. 100μF/10V M	CE1AMASDL101
C349		ELECTROLYTIC CAP. 470μF/10V M or	CE1AMASTL471
		ELECTROLYTIC CAP. 470μF/10V M	CE1AMASDL471
C351		CHIP CERAMIC CAP. CH J 100pF/50V	CHD1JJBCH101
C352		CHIP CERAMIC CAP. CH J 100pF/50V	CHD1JJBCH101
C353		ELECTROLYTIC CAP. 1μF/50V M or	CE1JMASTL1R0
		ELECTROLYTIC CAP. 1μF/50V M or	CE1JMASDL1R0
		ELECTROLYTIC CAP. 1μF/50V M	CE1JMASDL010
C362		ELECTROLYTIC CAP. 2.2μF/50V M or	CE1JMASTL2R2
		ELECTROLYTIC CAP. 2.2μF/50V M	CE1JMASDL2R2
C551		ELECTROLYTIC CAP. 47μF/35V M or	CE1GMASDL470
		ELECTROLYTIC CAP. 47μF/35V M	CE1GMASDL470
C552		FILM CAP.(P) 0.1μF/50V J or	CMA1JJS00104
		FILM CAP.(P) 0.1μF/50V J	CA1J104MS029
C554	A	ELECTROLYTIC CAP. 100μF/35V M or	CE1GMASDL101
	A	ELECTROLYTIC CAP. 100μF/35V M	CE1GMASDL101
C554	B	ELECTROLYTIC CAP. 470μF/35V M(VR) or	CE1GMZNTL471
	B	ELECTROLYTIC CAP. 470μF/35V M or	CE1GMZNDL471
	B	ELECTROLYTIC CAP. 470μF/35V M	CE1GMZADL471
C562		ELECTROLYTIC CAP. 2.2μF/50V M LL or	CE1JMASLL2R2
		ELECTROLYTIC CAP. 2.2μF/50V LL	CE1JMASLH2R2
C566		ELECTROLYTIC CAP. 1000μF/25V M or	CE1EMZNTL102
		ELECTROLYTIC CAP. 1000μF/25V M or	CE1EMZPDL102
		ELECTROLYTIC CAP. 1000μF/25V M	CE1EMZADL102
C568		ELECTROLYTIC CAP. 10μF/50V M or	CE1JMASTL100
		ELECTROLYTIC CAP. 10μF/50V M	CE1JMASDL100
C571▲	A	PP CAP. 0.33μF/250V J or	CT2E334MS041
▲	A	P.P. CAP. 0.33μF/200V J or	CA2D334VC012
▲	A	METALLIZED FILM CAP. 0.33μF/200V J	CT2D334F7001
C571▲	B	PP CAP. 0.47μF/250V J or	CT2E474MS041
▲	B	P.P.CAP. 0.47μF/200V J	CA2D474VC012
C574▲		ELECTROLYTIC CAP. 4.7μF/250V M or	CE2EMASTL4R7
▲		ELECTROLYTIC CAP. 4.7μF/250V M	CE2EMASDL4R7
C577▲		ELECTROLYTIC CAP. 47μF/35V M or	CE1GMASDL470
▲		ELECTROLYTIC CAP. 47μF/35V M	CE1GMASDL470
C578		FILM CAP.(P) 0.01μF/50V J or	CMA1JJS00103
		FILM CAP.(P) 0.01μF/50V J	CA1J103MS029
C580▲	A	PP CAP. 0.0082μF/1.6KV J or	CT3C822MS039
▲	A	PP CAP. 0.0082μF/1.6KV J or	CBH3CJQ00822
▲	A	P.P. CAP. 0.0082μF/1.6K J or	CA3C822VC011
▲	A	METALLIZED FILM CAP. 0.0082μF/1.6KV J	CT3C822F7002
C580▲	B	PP CAP. 0.01μF/1.6KV J or	CT3C103MS039
▲	B	PP CAP. 0.01μF/1.6KV J or	CBH3CJQ00103
▲	B	P.P.CAP. 0.01μF/1.6KV J or	CA3C103VC011
▲	B	METALLIZED FILM CAP. 0.01μF/1.6KV J	CT3C103F7002

Ref. No.	Mark	Description	Part No.
C581▲	B	CERAMIC CAP. LB 680pF/2K or	CA3D681KG004
▲	B	CERAMIC CAP. BN 680pF/2KV or	CCD3DKA0B681
▲	B	CERAMIC CAP. 680pF/2KV	CA3D681PAN04
C584▲		ELECTROLYTIC CAP. 1μF/160V M or	CE2CMASDL1R0
▲		ELECTROLYTIC CAP. 1μF/160V M	CE2CMASDL1R0
C594▲		ELECTROLYTIC CAP. 10μF/50V M or	CE1JMASTL100
▲		ELECTROLYTIC CAP. 10μF/50V M	CE1JMASTL100
C601▲		METALLIZED FILM CAP. 0.1μF/250V or	CT2E104MS037
▲		FILM CAP.(MP) 0.1μF/250V K or	CT2E104DC011
▲		METALLIZED FILM CAP. 0.1μF/275V K	CT2E104HJE06
C605		CERAMIC CAP. F Z 0.01μF/500V or	CCD2JZP0F103
		CERAMIC CAP. 0.01μF/AC250V	CCD2EZA0F103
C606		CERAMIC CAP. F Z 0.01μF/500V or	CCD2JZP0F103
		CERAMIC CAP. 0.01μF/AC250V	CCD2EZA0F103
C609		CERAMIC CAP. B K 1000pF/2KV or	CCD3DKD0B102
		CERAMIC CAP. B K 1000pF/2KV or	CCD3DKP0B102
		CERAMIC CAP. B K 1000pF/2KV	CA3D102MR030
C610▲	A	ALUMINIUM ELECTROLYTIC CAP. 150μF/200V or	CA2D151NC088
▲	A	ELECTROLYTIC CAPACITOR 150μF/200V	CA2D151S6012
C610▲	B	ELECTROLYTIC CAP. 220μF/200V or	CA2D221NC088
▲	B	ELECTROLYTIC CAP. 220μF/200V SL X	CA2D221S6003
C611		FILM CAP.(P) 0.068μF/50V J or	CMA1JJS00683
		FILM CAP.(P) 0.068μF/50V J	CA1J683MS029
C612		CERAMIC CAP. LB 330pF/2KV or	CA3D331KG004
		CERAMIC CAP. BN 330pF/2KV or	CCD3DKA0B331
		CERAMIC CAP. 330pF/2KV	CA3D331PAN04
C616	A	FILM CAP.(P) 0.039μF/50V J or	CMA1JJS00393
	A	FILM CAP.(P) 0.039μF/50V J	CA1J393MS029
C616	B	FILM CAP.(P) 0.056μF/50V J or	CMA1JJS00563
	B	FILM CAP.(P) 0.056μF/50V J	CA1J563MS029
C617		CERAMIC CAP.(AX) B K 330pF/50V	CCA1JKT0B331
If C642 is 0.01μF, then C643 is 0.01μF.			
C642▲		SAFETY CAP. 10000pF/250V or	CCG2EMA0F103
▲		SAFETY CAP. F M 0.01μF/250V or	CCG2EMP0F103
▲		CERAMIC CAP. 0.01μF F CS	CCG2HMNOF103
C643▲		SAFETY CAP. 10000pF/250V or	CCG2EMA0F103
▲		SAFETY CAP. F M 0.01μF/250V or	CCG2EMP0F103
▲		CERAMIC CAP. 0.01μF F CS	CCG2HMNOF103
If C643 is 4700pF, then JS642 (PCB JUMPER) is used.			
C643▲		SAFETY CAP. 4700pF/250V KX	CA2E472MR050
C650	A	CERAMIC CAP. LB 220pF/2KV or	CA3D221KG004
	A	CERAMIC CAP. BN J 220pF/2KV or	CCD3DKA0B221
	A	CERAMIC CAP. 220pF/2KV	CA3D221PAN04
C650	B	CERAMIC CAP. LB 470pF/2KV or	CA3D471KG004
	B	CERAMIC CAP. BN 470pF/2KV or	CCD3DKA0B471
	B	CERAMIC CAP. 470pF/2KV	CA3D471PAN04
C651	B	CERAMIC CAP. LB 470pF/2KV or	CA3D471KG004
	B	CERAMIC CAP. BN 470pF/2KV or	CCD3DKA0B471
	B	CERAMIC CAP. 470pF/2KV	CA3D471PAN04
C654▲		ELECTROLYTIC CAP. 1μF/50V M or	CE1JMASTL1R0
▲		ELECTROLYTIC CAP. 1μF/50V M or	CE1JMASDL1R0
▲		ELECTROLYTIC CAP. 1μF/50V M	CE1JMASDL010
C656▲		ELECTROLYTIC CAP. 100μF/160V M or	CE2CMZPTL101
▲		ELECTROLYTIC CAP. 100μF/160V M	CE2CMZNDL101
C657▲		ELECTROLYTIC CAP. 1000μF/35V M or	CE1GMZNTL102
▲		ELECTROLYTIC CAP. 1000μF/35V M or	CE1GMZNDL102
▲		ELECTROLYTIC CAP. 1000μF/35V M	CE1GMZADL102
C658▲		ELECTROLYTIC CAP. 1000μF/16V M(VR/HC) or	CE1CMZNTL102
▲		ELECTROLYTIC CAP. 1000μF/16V M or	CE1CMZPDL102

Ref. No.	Mark	Description	Part No.
▲		ELECTROLYTIC CAP. 1000µF/16V M	CE1CMZADL102
C667		ELECTROLYTIC CAP. 1µF/50V M or	CE1JMASTL1R0
		ELECTROLYTIC CAP. 1µF/50V M or	CE1JMASDL1R0
		ELECTROLYTIC CAP. 1µF/50V M	CE1JMASDL010
C681		ELECTROLYTIC CAP. 100µF/10V M or	CE1AMASTL101
		ELECTROLYTIC CAP. 100µF/10V M	CE1AMASDL101
C682		ELECTROLYTIC CAP. 100µF/10V M or	CE1AMASTL101
		ELECTROLYTIC CAP. 100µF/10V M	CE1AMASDL101
C683		ELECTROLYTIC CAP. 100µF/10V M or	CE1AMASTL101
		ELECTROLYTIC CAP. 100µF/10V M	CE1AMASDL101
C686		ELECTROLYTIC CAP. 33µF/16V M or	CE1CMASTL330
		ELECTROLYTIC CAP. 33µF/16V M	CE1CMASDL330
C687		ELECTROLYTIC CAP. 100µF/10V M or	CE1AMASTL101
		ELECTROLYTIC CAP. 100µF/10V M	CE1AMASDL101
C692		ELECTROLYTIC CAP. 47µF/160V M or	CE2CMZPTL470
		ELECTROLYTIC CAP. 47µF/160V M W/F	CE2CMZNDL470
C701		CHIP CERAMIC CAP. CH J 100pF/50V	CHD1JJBCH101
C711		CERAMIC CAP.(AX) X K 1200pF/16V	CDA1CKT0X122
C805		ELECTROLYTIC CAP. 220µF/16V M or	CE1CMASTL221
		ELECTROLYTIC CAP. 220µF/16V M	CE1CMASDL221
C811		ELECTROLYTIC CAP. 470µF/16V M or	CE1CMASTL471
		ELECTROLYTIC CAP. 470µF/16V M	CE1CMASDL471
C821		CERAMIC CAP.(AX) X K 3300pF/16V	CDA1CKT0X332
C822		CHIP CERAMIC CAP. F Z 0.22µF/16V	CHD1CZB0F224
C823		CHIP CERAMIC CAP. F Z 0.47µF/10V or	CHD1AZB0F474
		CHIP CERAMIC CAP. F Z 0.47µF/16V	CHD1CZB0F474
CONNECTORS			
CN571		CONNECTOR BASE, 5P TV-50P-05-V3 or	J3TVC05TG002
		CONNECTOR BASE, 5P RTB-1.5-5P	J3RTC05JG001
CN691		CONNECTOR BASE, 2P TV-50P-02-V3 or	J3TVC02TG002
		CONNECTOR BASE, 2P RTB-1.5-2P	J3RTC02JG001
CN801		STRAIGHT CONNECTOR BASE 00 8283 0212 00 000 or	J383C02UG002
		STRAIGHT PIN HEADER, 2P 173981-2	1770258
DIODES			
D101		SWITCHING DIODE 1SS133(T-77) or	QDTZ001SS133
		SWITCHING DIODE 1N4148	NDTZ001N4148
D102		SWITCHING DIODE 1SS133(T-77) or	QDTZ001SS133
		SWITCHING DIODE 1N4148	NDTZ001N4148
D111		ZENER DIODE MTZJT-775.6B or	QDTB00MTZJ5R6
		ZENER DIODE DZ-5.6BSBT265	NDTB00DZ5R6BS
D131		ZENER DIODE MTZJT-775.1B or	QDTB00MTZJ5R1
		ZENER DIODE DZ-5.1BSBT265	NDTB00DZ5R1BS
D151		ZENER DIODE MTZJT-775.6B or	QDTB00MTZJ5R6
		ZENER DIODE DZ-5.6BSBT265	NDTB00DZ5R6BS
D181▲		SWITCHING DIODE 1SS133(T-77) or	QDTZ001SS133
▲		SWITCHING DIODE 1N4148	NDTZ001N4148
D322		SWITCHING DIODE 1SS133(T-77) or	QDTZ001SS133
		SWITCHING DIODE 1N4148	NDTZ001N4148
D323		ZENER DIODE MTZJT-779.1B or	QDTB00MTZJ9R1
		ZENER DIODE DZ-9.1BSBT265	NDTB00DZ9R1BS
D326		SWITCHING DIODE 1SS133(T-77) or	QDTZ001SS133
		SWITCHING DIODE 1N4148	NDTZ001N4148
D350		SWITCHING DIODE 1SS133(T-77) or	QDTZ001SS133
		SWITCHING DIODE 1N4148	NDTZ001N4148
D351		SWITCHING DIODE 1SS133(T-77) or	QDTZ001SS133
		SWITCHING DIODE 1N4148	NDTZ001N4148
D352		SWITCHING DIODE 1SS133(T-77) or	QDTZ001SS133
		SWITCHING DIODE 1N4148	NDTZ001N4148
D551		DIODE 1N5399-B/P or	NDLZ001N5399
		RECTIFIER DIODE ERB12-06	QDQZ00ERB1206

Ref. No.	Mark	Description	Part No.
D561▲		SWITCHING DIODE 1SS133(T-77) or	QDTZ001SS133
▲		SWITCHING DIODE 1N4148	NDTZ001N4148
D562▲		SWITCHING DIODE 1SS133(T-77) or	QDTZ001SS133
▲		SWITCHING DIODE 1N4148	NDTZ001N4148
D568▲		SWITCHING DIODE 1SS133(T-77) or	QDTZ001SS133
▲		SWITCHING DIODE 1N4148	NDTZ001N4148
D569▲		ZENER DIODE MTZJT-7720B or	QDTB00MTZJ20
▲		ZENER DIODE DZ-20BSBT265	NDTB00DZ20BS
D571		DIODE FR104-B or	NDLZ000FR104
		RECTIFIER DIODE ERA22-02 or	QDPZ00ERA2202
		RECTIFIER DIODE 10ELS2	QDQZ0010ELS2
D572▲		RECTIFIER DIODE ERA22-02 or	QDPZ00ERA2202
▲		RECTIFIER DIODE 10ELS2	QDQZ0010ELS2
D573▲		PCB JUMPER D0.6-P5.0	JW5.0T
D584▲		SWITCHING DIODE 1SS133(T-77) or	QDTZ001SS133
▲		SWITCHING DIODE 1N4148	NDTZ001N4148
D593▲		ZENER DIODE MTZJT-7736B or	QDTB00MTZJ36
▲		ZENER DIODE DZ-36BSBT265	NDTB00DZ36BS
D595		SWITCHING DIODE 1SS133(T-77) or	QDTZ001SS133
		SWITCHING DIODE 1N4148	NDTZ001N4148
D597		ZENER DIODE MTZJT-776.8B or	QDTB00MTZJ6R8
		ZENER DIODE DZ-6.8BSBT265	NDTB00DZ6R8BS
D605▲		DIODE 1N5399-B/P or	NDLZ001N5399
▲		RECTIFIER DIODE ERB12-06	QDQZ00ERB1206
D606▲		DIODE 1N5399-B/P or	NDLZ001N5399
▲		RECTIFIER DIODE ERB12-06	QDQZ00ERB1206
D607▲		DIODE 1N5399-B/P or	NDLZ001N5399
▲		RECTIFIER DIODE ERB12-06	QDQZ00ERB1206
D608▲		DIODE 1N5399-B/P or	NDLZ001N5399
▲		RECTIFIER DIODE ERB12-06	QDQZ00ERB1206
D611		ZENER DIODE MTZJT-7715B or	QDTB00MTZJ15
		ZENER DIODE DZ-15BSBT265	NDTB00DZ15BS
D613		ZENER DIODE MTZJT-7718B or	QDTB00MTZJ18
		ZENER DIODE DZ-18BSBT265	NDTB00DZ18BS
D615▲		SWITCHING DIODE 1N4148 T-77	QDTZ001N4148
D616▲	B	ZENER DIODE MTZJT-7715B or	QDTB00MTZJ15
▲	B	ZENER DIODE DZ-15BSBT265	NDTB00DZ15BS
D621		ZENER DIODE MTZJT-773.0B or	QDTB00MTZJ3R0
		ZENER DIODE DZ-3.0BSBT265	NDTB00DZ3R0BS
D641		BEAD INDUCTORS FBR07HA121TB-00	LLBF00ZTU021
D642		SWITCHING DIODE 1SS133(T-77) or	QDTZ001SS133
		SWITCHING DIODE 1N4148	NDTZ001N4148
D651▲		FAST RECOVERY DIODE CA201-4 or	QDWZ00CA2014
▲		RECOVERY DIODE ERC18-04 or	QDZZ00ERC1804
▲		FAST RECOVERY DIODE ERC25-06	QDQZ00ERC2506
D652▲		DIODE FR154 or	NDLZ000FR154
▲		FAST RECOVERY DIODE ERB44-02	QDPZ00ERB4402
D653▲		DIODE FR154 or	NDLZ000FR154
▲		FAST RECOVERY DIODE ERB44-02	QDPZ00ERB4402
D654▲		SWITCHING DIODE 1SS133(T-77) or	QDTZ001SS133
▲		SWITCHING DIODE 1N4148	NDTZ001N4148
D657▲		DIODE 1ZC36 or	QDQZ0001ZC36
▲		ZENER DIODE RD39FB	QDQZ000RD39F
D658▲	A	ZENER DIODE MTZJT-7715B or	QDTB00MTZJ15
▲	A	ZENER DIODE DZ-15BSBT265	NDTB00DZ15BS
D660		SWITCHING DIODE 1SS133(T-77) or	QDTZ001SS133
		SWITCHING DIODE 1N4148	NDTZ001N4148
D661▲		SWITCHING DIODE 1SS133(T-77) or	QDTZ001SS133
▲		SWITCHING DIODE 1N4148	NDTZ001N4148
D662▲		ZENER DIODE MTZJT-776.8B or	QDTB00MTZJ6R8
▲		ZENER DIODE DZ-6.8BSBT265	NDTB00DZ6R8BS

Ref. No.	Mark	Description	Part No.
D666		ZENER DIODE MTZJF-7736B or ZENER DIODE DZ-36BSBT265	QDTB00MTZJ36 NDTB00DZ36BS
D671▲		SWITCHING DIODE 1SS133(T-77) or SWITCHING DIODE 1N4148	QDQT001SS133 NDT001N4148
D672		PCB JUMPER D0.6-P5.0	JW5.0T
D673		SWITCHING DIODE 1SS133(T-77) or SWITCHING DIODE 1N4148	QDQT001SS133 NDT001N4148
D682▲		ZENER DIODE MTZJF-775.6B or ZENER DIODE DZ-5.6BSBT265	QDTB00MTZJ5R6 NDTB00DZ5R6BS
D691▲		SWITCHING DIODE 1SS133(T-77) or SWITCHING DIODE 1N4148	QDQT001SS133 NDT001N4148
D694▲		PCB JUMPER D0.6-P5.0	JW5.0T
D696	B	SWITCHING DIODE 1SS133(T-77) or SWITCHING DIODE 1N4148	QDQT001SS133 NDT001N4148
D811▲		SWITCHING DIODE 1SS133(T-77) or SWITCHING DIODE 1N4148	QDQT001SS133 NDT001N4148
D831		SWITCHING DIODE 1SS133(T-77) or SWITCHING DIODE 1N4148	QDQT001SS133 NDT001N4148
ICS			
IC31		IC:VIF/SIF DETECTOR M61111FP	QSZA0SMB010
IC111▲		IC M61271M8-050FP-61 or IC:MICON/CHROMA M61271M8-050FP	QSZA0ORB127 QSZA0ORB127
IC151		IC:MEMORY S524C20D21 or IC:MEMORY AT24C02N-10SC or IC:(EEPROM) M24C02-MN6 or IC:MEMORY BR24C02F-W or IC:MEMORY BR24C02F or IC:EEPROM CAT24WC02JI	NSZBA0SSM028 NSMMA0SAZ012 NSMMA0SSS028 QSMBA0SRM003 QSMMA0SRM003 NSZBA0SBG001
IC551▲		VERTICAL OUTPUT IC LA78040A or VERTICAL OUTPUT IC AN5522	QSBBA0SSY003 QSZA0SMS002
IC601▲		PHOTOCOUPLER PS2501-1W or PHOTO COUPLER PS2501-1L or PHOTOCOUPLER LTV-817B-F or PHOTOCOUPLER LTV-817C-F	QPEW0PS25011 QPELOPS25011 NPEB0LTV817F NPEC0LTV817F
IC801		AUDIO AMP LA4224	QSZA0SSY005
COILS			
L1		PCB JUMPER D0.6-P5.0	JW5.0T
L3		INDUCTOR 22μH-K-5FT or INDUCTOR 22μH-K	LLARKBSTU220 LLARKDQKA220
L32		INDUCTOR 15μH-J-26T or INDUCTOR 15μH-K-26T	LLAXJATTU150 LLAXKDTKA150
L33		INDUCTOR 22μH-J-26T or INDUCTOR 22μH-K-26T	LLAXJATTU220 LLAXKDTKA220
L51		INDUCTOR 100μH-K-5FT or INDUCTOR 100μH-K	LLARKBSTU101 LLARKDQKA101
L111		PCB JUMPER D0.6-P5.0	JW5.0T
L301		INDUCTOR 100μH-K-5FT or INDUCTOR 100μH-K	LLARKBSTU101 LLARKDQKA101
L341		PCB JUMPER D0.6-P5.0	JW5.0T
L342		PCB JUMPER D0.6-P5.0	JW5.0T
L601▲		LINE FILTER TLF12UA302W1R0 or LINE FILTER 5.0MH 6Y075 or LINE FILTER LF005 or LINE FILTER UU10.5-A or LINE FILTER SA-91213B or LINE FILTER TLF14CB3321R0 or LINE FILTER 6.35MH UU10-002	LLBG00ZTU025 LLBG00ZKT004 LLBG00ZLH001 LLBG00ZY2008 LLBG00ZSA002 LLBG00ZTU012 LLBG00ZKV001
L692		CHOKE COIL 47μH-K or POT COIL 47μH K	LLBD00PKV007 LLBD**DMM001
TRANSISTORS			

Ref. No.	Mark	Description	Part No.
Q31		TRANSISTOR 2SC2785(F) or TRANSISTOR 2SC2785(H) or TRANSISTOR 2SC2785(J) or TRANSISTOR KTC3199(GR) or TRANSISTOR KTC3198(GR) or TRANSISTOR 2SC1815-GR(TPE2)	QQSF02SC2785 QQSH02SC2785 QQSJ02SC2785 NQS10KTC3199 NQS40KTC3198 QQS102SC1815
Q111		TRANSISTOR 2SC2785(F) or TRANSISTOR 2SC2785(H) or TRANSISTOR 2SC2785(J) or TRANSISTOR KTC3199(GR) or TRANSISTOR KTC3198(GR) or TRANSISTOR 2SC1815-GR(TPE2)	QQSF02SC2785 QQSH02SC2785 QQSJ02SC2785 NQS10KTC3199 NQS40KTC3198 QQS102SC1815
Q321▲		TRANSISTOR 2SC2785(F) or TRANSISTOR 2SC2785(H) or TRANSISTOR 2SC2785(J) or TRANSISTOR KTC3199(GR) or TRANSISTOR KTC3198(GR) or TRANSISTOR 2SC1815-GR(TPE2)	QQSF02SC2785 QQSH02SC2785 QQSJ02SC2785 NQS10KTC3199 NQS40KTC3198 QQS102SC1815
Q571▲	A	TRANSISTOR TT2138LS-YB11 or TRANSISTOR 2SC5884000RF	QQZZ00TT2138 QQZZ02SC5884
Q571▲	B	TRANSISTOR TT2140LS-YB11 or TRANSISTOR 2SC5885000RF	QQZZ00TT2140 QQZZ02SC5885
Q572		TRANSISTOR 2SC1627Y-TPE2	QQSY02SC1627
Q601▲		MOS FET 2SK2662	QF5Z02SK2662
Q601▲	A	FET 2SK3543	QFWZ02SK3543
Q602▲		TRANSISTOR 2SC2120-O-TPE2 or TRANSISTOR 2SC2120-Y(TPE2)	QQS002SC2120 QQSY02SC2120
Q662▲		TRANSISTOR 2SC2785(F) or TRANSISTOR 2SC2785(H) or TRANSISTOR 2SC2785(J) or TRANSISTOR KTC3199(GR) or TRANSISTOR KTC3198(GR) or TRANSISTOR 2SC1815-GR(TPE2)	QQSF02SC2785 QQSH02SC2785 QQSJ02SC2785 NQS10KTC3199 NQS40KTC3198 QQS102SC1815
Q671▲		TRANSISTOR 2SA1175(F) or TRANSISTOR KTA1267(GR) or TRANSISTOR KTA1266(GR) or TRANSISTOR 2SA1015-GR(TPE2)	QQSF02SA1175 NQS10KTA1267 NQS40KTA1266 QQS102SA1015
Q675		TRANSISTOR 2SC2785(F) or TRANSISTOR 2SC2785(H) or TRANSISTOR 2SC2785(J) or TRANSISTOR KTC3199(GR) or TRANSISTOR KTC3198(GR) or TRANSISTOR 2SC1815-GR(TPE2)	QQSF02SC2785 QQSH02SC2785 QQSJ02SC2785 NQS10KTC3199 NQS40KTC3198 QQS102SC1815
Q676		RES. BUILT-IN TRANSISTOR BA1F4M-T or RES. BUILT-IN TRANSISTOR KRC103M	QQSZ00BA1F4M NQSZ0KRC103M
Q681		TRANSISTOR 2SC2120-O-TPE2 or TRANSISTOR 2SC2120-Y(TPE2) or TRANSISTOR KTC3203(Y)	QQS002SC2120 QQSY02SC2120 NQSY0KTC3203
Q682		TRANSISTOR 2SC2120-O-TPE2 or TRANSISTOR 2SC2120-Y(TPE2) or TRANSISTOR KTC3203(Y)	QQS002SC2120 QQSY02SC2120 NQSY0KTC3203
Q683		TRANSISTOR 2SC2120-O-TPE2 or TRANSISTOR 2SC2120-Y(TPE2) or TRANSISTOR KTC3203(Y)	QQS002SC2120 QQSY02SC2120 NQSY0KTC3203
Q696	B	RES. BUILT-IN TRANSISTOR BA1F4M-T or RES. BUILT-IN TRANSISTOR KRC103M	QQSZ00BA1F4M NQSZ0KRC103M
RESISTORS			
R3		CHIP RES. 1/10W J 0 Ω	RRXAJB5Z0000
R4		CHIP RES.(1608) 1/10W J 100 Ω	RRXAJB5Z0101

Ref. No.	Mark	Description	Part No.
R5		CHIP RES.(1608) 1/10W J 100 Ω	RRXAJB5Z0101
R31		CHIP RES.(1608) 1/10W J 2.2k Ω	RRXAJB5Z0222
R32		CHIP RES.(1608) 1/10W J 390 Ω	RRXAJB5Z0391
R33		CHIP RES.(1608) 1/10W J 270 Ω	RRXAJB5Z0271
R34		CHIP RES.(1608) 1/10W J 220 Ω	RRXAJB5Z0221
R36		CHIP RES.(1608) 1/10W J 10k Ω	RRXAJB5Z0103
R37		CHIP RES.(1608) 1/10W J 220 Ω	RRXAJB5Z0221
R38		CHIP RES.(1608) 1/10W J 3.3k Ω	RRXAJB5Z0332
R39		CHIP RES.(1608) 1/10W J 27k Ω	RRXAJB5Z0273
R41		CHIP RES.(1608) 1/10W J 6.8k Ω	RRXAJB5Z0682
R43		CHIP RES.(1608) 1/10W J 12k Ω	RRXAJB5Z0123
R45		CHIP RES.(1608) 1/10W J 22k Ω	RRXAJB5Z0223
R51		CHIP RES.(1608) 1/10W J 220k Ω	RRXAJB5Z0224
R52		CHIP RES.(1608) 1/10W J 220k Ω	RRXAJB5Z0224
R102		CHIP RES.(1608) 1/10W J 2.2k Ω	RRXAJB5Z0222
R103		CHIP RES.(1608) 1/10W J 1.8k Ω	RRXAJB5Z0182
R104		CHIP RES.(1608) 1/10W J 3.3k Ω	RRXAJB5Z0332
R105		CHIP RES.(1608) 1/10W J 4.7k Ω	RRXAJB5Z0472
R106		CHIP RES.(1608) 1/10W J 8.2k Ω	RRXAJB5Z0822
R111▲		CARBON RES. 1/4W J 100 Ω or	RCX4JATZ0101
▲		CARBON RES. 1/6W J 100 Ω	RCX6JATZ0101
R112		CHIP RES.(1608) 1/10W J 10k Ω	RRXAJB5Z0103
R113		CHIP RES.(1608) 1/10W J 470k Ω	RRXAJB5Z0474
R114		CHIP RES.(1608) 1/10W J 1k Ω	RRXAJB5Z0102
R115		CHIP RES.(1608) 1/10W J 2.7k Ω	RRXAJB5Z0272
R132		CHIP RES.(1608) 1/10W J 6.8k Ω	RRXAJB5Z0682
R133		CHIP RES. 1/10W J 0 Ω	RRXAJB5Z0000
R135		CHIP RES.(1608) 1/10W J 2.2k Ω	RRXAJB5Z0222
R136		CHIP RES.(1608) 1/10W J 100k Ω	RRXAJB5Z0104
R137		CHIP RES.(1608) 1/10W J 100 Ω	RRXAJB5Z0101
R138		CHIP RES.(1608) 1/10W J 220k Ω	RRXAJB5Z0224
R139		CHIP RES.(1608) 1/10W J 22k Ω	RRXAJB5Z0223
R140		CHIP RES.(1608) 1/10W J 1k Ω	RRXAJB5Z0102
R141		PCB JUMPER D0.6-P5.0	JW5.0T
R151		CHIP RES.(1608) 1/10W J 4.7k Ω	RRXAJB5Z0472
R155		CARBON RES. 1/4W J 100 Ω or	RCX4JATZ0101
		CARBON RES. 1/6W J 100 Ω	RCX6JATZ0101
R156		CARBON RES. 1/4W J 1k Ω or	RCX4JATZ0102
		CARBON RES. 1/6W J 1k Ω	RCX6JATZ0102
R161		CHIP RES.(1608) 1/10W J 10k Ω	RRXAJB5Z0103
R162		CHIP RES.(1608) 1/10W J 10k Ω	RRXAJB5Z0103
R163		CHIP RES.(1608) 1/10W J 6.8k Ω	RRXAJB5Z0682
R164		CHIP RES.(1608) 1/10W J 22k Ω	RRXAJB5Z0223
R166		CHIP RES.(1608) 1/10W J 4.7k Ω	RRXAJB5Z0472
R168		CHIP RES.(1608) 1/10W J 4.7k Ω	RRXAJB5Z0472
R301		CHIP RES.(1608) 1/10W J 6.8k Ω	RRXAJB5Z0682
R302		CHIP RES.(1608) 1/10W J 100 Ω	RRXAJB5Z0101
R303		CHIP RES.(1608) 1/10W J 470 Ω	RRXAJB5Z0471
R321		CHIP RES.(1608) 1/10W J 470 Ω	RRXAJB5Z0471
R322		CHIP RES. 1/10W J 0 Ω	RRXAJB5Z0000
R323▲		CARBON RES. 1/4W J 2.2k Ω	RCX4JATZ0222
R326		CHIP RES.(1608) 1/10W J 100 Ω	RRXAJB5Z0101
R327		CHIP RES. 1/10W J 0 Ω	RRXAJB5Z0000
R328		CHIP RES.(1608) 1/10W J 4.7k Ω	RRXAJB5Z0472
R329	A	CHIP RES.(1608) 1/10W J 39k Ω or	RRXAJB5Z0393
	A	CHIP RES.(1608) 1/10W J 39k Ω	RRXAJB5Z0393
R329	B	CHIP RES.(1608) 1/10W J 47k Ω or	RRXAJB5Z0473
	B	CHIP RES.(1608) 1/10W J 47k Ω	RRXAJB5Z0473
R330		CHIP RES.(1608) 1/10W J 1k Ω	RRXAJB5Z0102
R331		CHIP RES. 1/10W J 0 Ω	RRXAJB5Z0000
R342		CHIP RES. 1/10W J 0 Ω	RRXAJB5Z0000

Ref. No.	Mark	Description	Part No.
R344		CHIP RES.(1608) 1/10W J 6.8k Ω	RRXAJB5Z0682
R345		CHIP RES.(1608) 1/10W J 10k Ω	RRXAJB5Z0103
R346		CHIP RES.(1608) 1/10W J 2.7k Ω	RRXAJB5Z0272
R347		CHIP RES.(1608) 1/10W J 220 Ω	RRXAJB5Z0221
R348		CHIP RES.(1608) 1/10W J 27k Ω	RRXAJB5Z0273
R350		CHIP RES.(1608) 1/10W J 100 Ω	RRXAJB5Z0101
R352		CHIP RES.(1608) 1/10W J 100 Ω	RRXAJB5Z0101
R354		CHIP RES.(1608) 1/10W J 100 Ω	RRXAJB5Z0101
R355	A	CHIP RES.(1608) 1/10W J 27k Ω	RRXAJB5Z0273
R355	B	CHIP RES.(1608) 1/10W J 39k Ω	RRXAJB5Z0393
R391		CHIP RES.(1608) 1/10W J 1k Ω	RRXAJB5Z0102
R392		CHIP RES.(1608) 1/10W J 100 Ω	RRXAJB5Z0101
R393		CHIP RES.(1608) 1/10W J 100 Ω	RRXAJB5Z0101
R551		CHIP RES.(1608) 1/10W J 4.7 Ω	RRXAJB5Z04R7
R552▲		CARBON RES. 1/4W J 3.9 Ω	RCX4JATZ03R9
R553▲	A	CARBON RES. 1/4W J 1 Ω or	RCX4JATZ0010
▲	A	CARBON RES. 1/4W J 1 Ω	RCX6JATZ0010
R553▲	B	CARBON RES. 1/4W J 3.9 Ω	RCX4JATZ03R9
R554▲	A	CARBON RES. 1/4W J 1 Ω or	RCX4JATZ0010
▲	A	CARBON RES. 1/4W J 1 Ω	RCX6JATZ0010
R554▲	B	CARBON RES. 1/4W J 3.9 Ω	RCX4JATZ03R9
R556		CARBON RES. 1/4W J 1k Ω or	RCX4JATZ0102
		CARBON RES. 1/6W J 1k Ω	RCX6JATZ0102
R557		CARBON RES. 1/4W J 1k Ω or	RCX4JATZ0102
		CARBON RES. 1/6W J 1k Ω	RCX6JATZ0102
R558		CARBON RES. 1/4W J 3.3k Ω	RCX4JATZ0332
R559		CARBON RES. 1/4W J 3.3k Ω	RCX4JATZ0332
R561		CHIP RES.(1608) 1/10W J 470 Ω	RRXAJB5Z0471
R562	A	CHIP RES.(1608) 1/10W J 3.3k Ω	RRXAJB5Z0332
R562	B	CHIP RES.(1608) 1/10W J 4.7k Ω	RRXAJB5Z0472
R563	A	CHIP RES.(1608) 1/10W J 10k Ω	RRXAJB5Z0103
R563	B	CHIP RES.(1608) 1/10W J 22k Ω	RRXAJB5Z0223
R564	A	CHIP RES.(1608) 1/10W J 22k Ω	RRXAJB5Z0223
R564	B	CHIP RES.(1608) 1/10W J 56k Ω	RRXAJB5Z0563
R566	A	CARBON RES. 1/4W 2.2 Ω J or	RCX4JATZ02R2
	A	CARBON RES. 1/6W J 2.2 Ω	RCX6JATZ02R2
R566	B	CARBON RES. 1/4W J 3.3 Ω or	RCX4JATZ03R3
	B	CARBON RES. 1/6W J 3.3 Ω	RCX6JATZ03R3
R567	B	CARBON RES. 1/4W J 3.3 Ω or	RCX4JATZ03R3
	B	CARBON RES. 1/6W J 3.3 Ω	RCX6JATZ03R3
R569▲		CHIP RES.(1608) 1/10W J 6.8k Ω	RRXAJB5Z0682
R571▲	A	METAL OXIDE FILM RES. 2W J 470 Ω or	RN02471ZU001
▲	A	METAL OXIDE FILM RES. 2W J 470 Ω	RN02471DP004
R571▲	B	METAL OXIDE FILM RES. 2W J 1k Ω or	RN02102ZU001
▲	B	METAL OXIDE FILM RES. 2W J 1k Ω	RN02102DP004
R572▲	B	METAL OXIDE FILM RES. 2W J 1k Ω or	RN02102ZU001
▲	B	METAL OXIDE FILM RES. 2W J 1k Ω	RN02102DP004
R575▲	A	CARBON RES. 1/4W J 47 Ω or	RCX4JATZ0470
▲	A	CARBON RES. 1/6W J 47 Ω	RCX6JATZ0470
R575▲	B	CARBON RES. 1/4W J 15 Ω or	RCX4JATZ0150
▲	B	CARBON RES. 1/6W J 15 Ω	RCX6JATZ0150
R576▲	A	CARBON RES. 1/4W J 47 Ω or	RCX4JATZ0470
▲	A	CARBON RES. 1/6W J 47 Ω	RCX6JATZ0470
R576▲	B	CARBON RES. 1/4W J 15 Ω or	RCX4JATZ0150
▲	B	CARBON RES. 1/6W J 15 Ω	RCX6JATZ0150
R577▲	A	PCB JUMPER D0.6-P5.0	JW5.0T
R577▲	B	CARBON RES. 1/4W J 15 Ω or	RCX4JATZ0150
▲	B	CARBON RES. 1/6W J 15 Ω	RCX6JATZ0150
R578	A	CARBON RES. 1/4W J 560 Ω or	RCX4JATZ0561
	A	CARBON RES. 1/6W J 560 Ω	RCX6JATZ0561
R578	B	CARBON RES. 1/4W J 390 Ω or	RCX4JATZ0391

Ref. No.	Mark	Description	Part No.
	B	CARBON RES. 1/6W J 390 Ω	RCX6JATZ0391
R579		CHIP RES.(1608) 1/10W J 1k Ω	RRXAJB5Z0102
R581		PCB JUMPER D0.6-P5.0	JW5.0T
R583▲	A	METAL OXIDE FILM RES. 2W J 1.8 Ω or	RN02JLZ01R8
▲	A	METAL FILM RES.(STRAIGHT)2W J 1.8 Ω	RN02JZP01R8
R583▲	B	METAL OXIDE FILM RES. 2W J 2.7 Ω or	RN02JLZ02R7
▲	B	METAL OXIDE RESISTOR 2W 2.7 Ω(J)	RN02JZP02R7
R584▲		CARBON RES. 1/4W J 1k Ω or	RCX4JATZ0102
▲		CARBON RES. 1/6W J 1k Ω	RCX6JATZ0102
R587	A	CARBON RES. 1/4W J 100k Ω	RCX4JATZ0104
R587	B	CARBON RES. 1/4W J 270k Ω	RCX4JATZ0274
R588▲		CARBON RES. 1/4W J 100k Ω	RCX4JATZ0104
R589	A	CARBON RES. 1/4W J 120k Ω	RCX4JATZ0124
R589	B	CARBON RES. 1/4W J 100k Ω	RCX4JATZ0104
R591▲		CHIP RES.(1608) 1/10W J 180k Ω	RRXAJB5Z0184
R592▲		CHIP RES.(1608) 1/10W J 100k Ω	RRXAJB5Z0104
R593▲		CHIP RES.(1608) 1/10W J 68k Ω	RRXAJB5Z0683
R594▲		CHIP RES.(1608) 1/10W J 100k Ω	RRXAJB5Z0104
R596		CHIP RES.(1608) 1/10W J 100 Ω	RRXAJB5Z0101
R597		CARBON RES. 1/4W J 8.2k Ω	RCX4JATZ0822
R598▲		CARBON RES. 1/4W J 47k Ω	RCX4JATZ0473
R599▲		CHIP RES.(1608) 1/10W J 22k Ω	RRXAJB5Z0223
R601▲		CEMENT RES. 5W K 1.2 Ω or	RW051R2DP005
▲		CEMENT RESISTOR 5W K 1.2 Ω or	RW051R2PG001
▲		CEMENT RESISTOR 5W J 1.2 Ω or	RW051R2Y4001
▲		CEMENT RES. 3W K 1.2 Ω	RW031R2PG007
R602▲		CARBON RES. 1/4W J 820k Ω	RCX4JATZ0824
R603		CARBON RES. 1/4W J 820k Ω	RCX4JATZ0824
R611		CARBON RES. 1/4W J 270 Ω or	RCX4JATZ0271
		CARBON RES. 1/6W J 270 Ω	RCX6JATZ0271
R612		CARBON RES. 1/4W J 270 Ω or	RCX4JATZ0271
		CARBON RES. 1/6W J 270 Ω	RCX6JATZ0271
R613▲	A	METAL OXIDE FILM RES. 2W J 0.47 Ω or	RN02JLZ0R47
▲	A	METAL RES. 2W J 0.47 Ω	RN02JZP0R47
R613▲	B	METAL OXIDE FILM RES. 2W J 0.33 Ω or	RN02JLZ0R33
▲	B	METAL RES 2W J 0.33 Ω	RN02JZP0R33
R616		CARBON RES. 1/4W J 1.5k Ω	RCX4JATZ0152
R621		CARBON RES. 1/4W J 1.2k Ω	RCX4JATZ0122
R622	A	CARBON RES. 1/4W J 150 Ω or	RCX4JATZ0151
	A	CARBON RES. 1/6W J 150 Ω	RCX6JATZ0151
R622	B	CARBON RES. 1/4W J 82 Ω or	RCX4JATZ0820
	B	CARBON RES. 1/6W J 82 Ω	RCX6JATZ0820
R624		PCB JUMPER D0.6-P5.0	JW5.0T
R653		CHIP RES.(1608) 1/10W J 15k Ω	RRXAJB5Z0153
R654▲	A	CARBON RES. 1/4W J 3.3k Ω	RCX4JATZ0332
R654▲	B	CARBON RES. 1/4W J 2.7k Ω	RCX4JATZ0272
R655▲		CARBON RES. 1/4W J 1k Ω or	RCX4JATZ0102
▲		CARBON RES. 1/6W J 1k Ω	RCX6JATZ0102
R656▲		CHIP RES.(1608) 1/10W J 15k Ω	RRXAJB5Z0153
R657▲		CHIP RES.(1608) 1/10W J 15k Ω	RRXAJB5Z0153
R660		CARBON RES. 1/4W J 1k Ω or	RCX4JATZ0102
		CARBON RES. 1/6W J 1k Ω	RCX6JATZ0102
R661▲	A	CARBON RES. 1/4W J 180k Ω	RCX4JATZ0184
R661▲	B	CARBON RES. 1/4W J 220k Ω	RCX4JATZ0224
R662▲	A	CARBON RES. 1/4W J 33k Ω	RCX4JATZ0333
R662▲	B	CARBON RES. 1/4W J 6.8k Ω	RCX4JATZ0682
R664▲		CHIP RES.(1608) 1/10W J 12k Ω	RRXAJB5Z0123
R665▲		CHIP RES.(1608) 1/10W J 4.7k Ω	RRXAJB5Z0472
R666▲		METAL OXIDE FILM RES. 2W J 15k Ω	RN02153DP004
R667▲		PCB JUMPER D0.6-P5.0	JW5.0T

Ref. No.	Mark	Description	Part No.
R668▲		METAL OXIDE FILM RES. 1W J 56k Ω	RN01563DP003
R671		CARBON RES. 1/4W J 3.3k Ω	RCX4JATZ0332
R672		CARBON RES. 1/4W J 3.3k Ω	RCX4JATZ0332
R673		CARBON RES. 1/4W J 100k Ω	RCX4JATZ0104
R675		CARBON RES. 1/4W J 22k Ω	RCX4JATZ0223
R676		CARBON RES. 1/4W J 10k Ω	RCX4JATZ0103
R681▲		CARBON RES. 1/4W J 12 Ω or	RCX4JATZ0120
▲		CARBON RES. 1/6W J 12 Ω	RCX6JATZ0120
R682▲		METAL OXIDE FILM RES. 1W J 56 Ω or	RN01560ZU001
▲		METAL OXIDE FILM RES. 1W J 56 Ω	RN01560DP003
R683▲		METAL OXIDE FILM RES. 1W J 39 Ω or	RN01390ZU001
▲		METAL OXIDE FILM RES. 1W J 39 Ω	RN01390DP003
R684		CARBON RES. 1/4W J 47 Ω or	RCX4JATZ0470
		CARBON RES. 1/6W J 47 Ω	RCX6JATZ0470
R685		CARBON RES. 1/4W J 47 Ω or	RCX4JATZ0470
		CARBON RES. 1/6W J 47 Ω	RCX6JATZ0470
R686		CARBON RES. 1/4W J 100 Ω or	RCX4JATZ0101
		CARBON RES. 1/6W J 100 Ω	RCX6JATZ0101
R687		CARBON RES. 1/4W J 100 Ω or	RCX4JATZ0101
		CARBON RES. 1/6W J 100 Ω	RCX6JATZ0101
R691▲		CARBON RES. 1/4W J 15k Ω	RCX4JATZ0153
R696	B	CARBON RES. 1/4W J 10 Ω or	RCX4JATZ0100
	B	CARBON RES. 1/6W J 10 Ω	RCX6JATZ0100
R701		CHIP RES.(1608) 1/10W J 75 Ω	RRXAJB5Z0750
R702		CHIP RES. 1/10W J 0 Ω	RRXAJB5Z0000
R711		CHIP RES.(1608) 1/10W J 47k Ω	RRXAJB5Z0473
R712		CHIP RES.(1608) 1/10W J 3.3k Ω	RRXAJB5Z0332
R801		CARBON RES. 1/2W J 100 Ω or	RCX2JZQZ0101
		CARBON RES. 1/2W J 100 Ω	RCX2JZPZ0101
R810▲		METAL OXIDE FILM RES. 1W J 10 Ω or	RN01100ZU001
▲		METAL OXIDE FILM RES. 1W J 10 Ω	RN01100DP003
R811▲		CHIP RES.(1608) 1/10W J 2.2k Ω	RRXAJB5Z0222
R812▲		CHIP RES.(1608) 1/10W J 2.2k Ω	RRXAJB5Z0222
R821		CHIP RES.(1608) 1/10W J 15k Ω	RRXAJB5Z0153
R822		CHIP RES.(1608) 1/10W J 5.6k Ω	RRXAJB5Z0562
R831		CHIP RES.(1608) 1/10W J 470k Ω	RRXAJB5Z0474
R832		CHIP RES.(1608) 1/10W J 6.8k Ω	RRXAJB5Z0682
SWITCHES			
SW101		TACT SWITCH SKQSAB or	SST0101AL038
		TACT SWITCH KSM0612B or	SST0101HH003
		TACT SWITCH SKHHAM	SST0101AL029
SW102		TACT SWITCH SKQSAB or	SST0101AL038
		TACT SWITCH KSM0612B or	SST0101HH003
		TACT SWITCH SKHHAM	SST0101AL029
SW103		TACT SWITCH SKQSAB or	SST0101AL038
		TACT SWITCH KSM0612B or	SST0101HH003
		TACT SWITCH SKHHAM	SST0101AL029
SW104		TACT SWITCH SKQSAB or	SST0101AL038
		TACT SWITCH KSM0612B or	SST0101HH003
		TACT SWITCH SKHHAM	SST0101AL029
SW105		TACT SWITCH SKQSAB or	SST0101AL038
		TACT SWITCH KSM0612B or	SST0101HH003
		TACT SWITCH SKHHAM	SST0101AL029
SW106		TACT SWITCH SKQSAB or	SST0101AL038
		TACT SWITCH KSM0612B or	SST0101HH003
		TACT SWITCH SKHHAM	SST0101AL029
MISCELLANEOUS			
AC601▲		AC CORD LA-2366 or	WAC0172LW006
▲		AC CORD WAC0172AS006 or	WAC0172AS006
▲		AC CORD WAC0172LTE01 or	WAC0172LTE01

Ref. No.	Mark	Description	Part No.
▲		AC CORD A0A0280-007 or	WAC0172LTE04
▲		AC CORD PB8K9F9110A-057	WAC0172LW008
BC101		BEAD INDUCTORS FBR07HA121TB-00	LLBF00ZTU021
BC571		BEAD INDUCTORS FBA04HA600VB-00	LLBF00STU026
BC601		BEAD INDUCTORS FBR07HA121TB-00	LLBF00ZTU021
BC602		BEAD INDUCTORS FBR07HA121TB-00	LLBF00ZTU021
BC651		BEAD INDUCTORS FBR07HA121TB-00	LLBF00ZTU021
BC652		BEAD INDUCTORS FBR07HA121TB-00	LLBF00ZTU021
BC653		BEAD INDUCTORS FBR07HA121TB-00	LLBF00ZTU021
BC691		BEAD INDUCTORS FBR07HA121TB-00	LLBF00ZTU021
BC692		BEAD INDUCTORS FBR07HA121TB-00	LLBF00ZTU021
JS642		PCB JUMPER D0.6-P7.5	JW7.5T
CF31		CERAMIC TRAP 4.5MHz or	FBE455PMR003
		CERAMIC TRAP 4.5MHz	FBE455PMS002
CF32		CERAMIC FILTER SFSRA4M50CF00-B0 or	FBB455PMR004
		CERAMIC FILTER 4.5MHz	FBB455PMS001
CLN301	A	WIRE ASSEMBLY WX1L9700-104	WX1L9700-104
CLN301	B	WIRE ASSEMBLY WX1L1100-102	WX1L1100-102
F601▲		FUSE 4A/125V 237 TYPE or	PAGJ20CAG402
▲		FUSE STC4A125V U/CT or	PAGE20CW3402
▲		FUSE 4.00A/125V	PAGG20CNG402
FH601		FUSE HOLDER MSF-015 or	XH01200LY001
		FUSE HOLDER FH-V-03078	XH01200DK001
FH602		FUSE HOLDER MSF-015 or	XH01200LY001
		FUSE HOLDER FH-V-03078	XH01200DK001
GP641▲		GAP: FNR-G3.10D	FAZ000LD6005
J115		CHIP RES. 1/10W J 0 Ω	RRXAJB5Z0000
JK701		RCA JACK(YELLOW) MTJ-032-06B-20 or	JXRL010LY050
		RCA JACK 1P AV-8.4-9Y	JXRL010RP010
JK702		RCA JACK(WHITE) MTJ-032-06B-22 or	JXRL010LY052
		RCA JACK 1P AV-8.4-9W	JXRL010RP011
JK801		EARPHONE JACK HTJ-035-1ZEBTZ or	JYSL030GE001
		EARPHONE JACK MSJ-035-12APC or	JYSL030LY001
		EARPHONE JACK HSJ1403-01-010 or	JYSL030HD002
		EARPHONE JACK LGY6501-0600	JYSL030SR001
JS112		CHIP RES. 1/10W J 0 Ω	RRXAJB5Z0000
JS113		CHIP RES. 1/10W J 0 Ω	RRXAJB5Z0000
JS601	A	PCB JUMPER D0.6-P5.0	JW5.0T
JS802		PCB JUMPER D0.6-P5.0	JW5.0T
PB1		HEAT SINK(PGW) L6400UZ	0EM407501
PB2	A	HEAT SINK(PGY)ASSEMBLY L6300UZ	0EM407516
PB2	B	HEAT SINK(PGX)ASSEMBLY L6400UZ	0EM407502
PB3		CLOTH(65) L7735TR:65X10X0.5T	0EM402149
PL1		SCREW, B-TIGHT M3X8 BIND HEAD+ or	GBMB3080
		SCREW, B-TIGHT M3X8 BIND HEAD+	GBMB3080
PS691▲		THERMISTOR ZPB45BL7R0A	QNZZ45BL7R0A
RCV101		REMOCON RECEIVE UNIT MIM-93M8DKL or	USESJRSUNT02
		REMOCON RECEIVE UNIT PIC-26042SR-2 or	USESJRSKK032
		REMOCON RECEIVE UNIT PIC-37042SR	USESJRSKK034
RL601▲	B	POWER RELAY SDT-S-112LMR or	MRNDC12QN014
▲	B	POWER RELAY RPEF-12-901 or	MRNDC12KB002
▲	B	RELAY ALKS321	MRNDC12MS013
SA601▲		SURGE ABSORBER JVR-07N471K or	NVQZVR07N471
▲		SURGE ABSORBER CNR-10D471K or	NVQZR10D471K
▲		SURGE ABSORBER CNR-07D471K or	NVQZR07D471K
▲		SURGE ABSORBER PVR-07D471KB or	NVQZ07D471KB
▲		SURGE ABSORBER AVR-S07D471KAAS or	QVQZ0AVRS07D

Ref. No.	Mark	Description	Part No.
▲		VARISTOR ENC471D-07A	QVQZ0471D07A
SF1		SAW FILTER SAFGM45M7VHHzC0B03	FBB456PMR008
T571▲	A	FLYBACK TRANSFORMER JF0501-2418 or	LTF00CPXB026
▲	A	FLYBACK TRANS BSC21-2016S or	LTF00CPS2040
▲	A	FLYBACK TRANS BSC25-0241 or	LTF00CPP1007
▲	A	FLYBACK TRANS FNI14A001	LTF00CPSM018
T571▲	B	FLYBACK TRANSFORMER JF0501-2419 or	LTF00CPXB027
▲	B	FLYBACK TRANS BSC21-2047S or	LTF00CPS2050
▲	B	FLYBACK TRANS BSC25-0243 or	LTF00CPP1008
▲	B	FLYBACK TRANS FNI20A001	LTF00CPSM019
T572	A	HORIZONTAL DRIVE TRANS LP2-005	LTH00CPA5005
T572	B	HORIZONTAL DRIVE TRANS LP2-004	LTH00CPA5004
T601▲	A	SWITCHING TRANS 02Y0438	LTT00CPKT099
T601▲	B	SWITCHING TRANS KD-01743 or	LTT00CPKT088
▲	B	SWITCHING TRANS CSA-SW0049	LTT00CPSA122
TP300		PCB JUMPER D0.6-P12.5	JW12.5T
TP601		PCB JUMPER D0.6-P10.0	JW10.0T
TU1		TUNER UNIT TEQH9-001A	UTUNNTUAL032
VR661▲	A	CARBON P.O.T. 30k Ω B or	VR66130KA011
▲	A	CARBON P.O.T. 30k Ω B	VR66130HH014
VR661▲	B	CARBON P.O.T. 50k Ω B or	VR66150KB011
▲	B	CARBON P.O.T. 50k Ω B	VR66150HH014
X301		X'TAL 3.579545 MHz or	FXD355LLN003
		X'TAL 3.579545MHz(30PPM)	FXD355LCHE01

CRT CBA

Ref. No.	Mark	Description	Part No.
		CRT CBA Consists of the following	-----
CAPACITORS			
C501	A	CHIP CERAMIC CAP. CH J 270pF/50V	CHD1JJBCH271
C501	B	CHIP CERAMIC CAP. CH J 330pF/50V	CHD1JJBCH331
C502		CHIP CERAMIC CAP. CH J 270pF/50V	CHD1JJBCH271
C503		CHIP CERAMIC CAP. CH J 330pF/50V	CHD1JJBCH331
C504		ELECTROLYTIC CAP. 47μF/16V M or	CE1CMASL470
		ELECTROLYTIC CAP. 47μF/16V M	CE1CMASDL470
C510		CERAMIC CAP. B K 1000pF/2KV or	CCD3DKD0B102
		CERAMIC CAP. B K 1000pF/2KV or	CCD3DKP0B102
		CERAMIC CAP. B K 1000pF/2KV	CA3D102MR030
COILS			
L501	A	INDUCTOR 150μH-J-5FT or	LLARJCSU151
	A	INDUCTOR 150μH-K-5FT	LLARKDSKA151
L501	B	INDUCTOR 180μH-J-5FT or	LLARJCSU181
	B	INDUCTOR 180μH-K-5FT	LLARKDSKA181
TRANSISTORS			
Q501		TRANSISTOR 2SC2482 TPE6 or	QQS202SC2482
		TRANSISTOR 2SC3468(E)-AE or	QQSE02SC3468
		TRANSISTOR 2SC3468(D)-AE or	QQSD02SC3468
		TRANSISTOR KTC3207	NQS20KTC3207
Q502		TRANSISTOR 2SC2482 TPE6 or	QQS202SC2482
		TRANSISTOR 2SC3468(E)-AE or	QQSE02SC3468
		TRANSISTOR 2SC3468(D)-AE or	QQSD02SC3468
		TRANSISTOR KTC3207	NQS20KTC3207
Q503		TRANSISTOR 2SC2482 TPE6 or	QQS202SC2482
		TRANSISTOR 2SC3468(E)-AE or	QQSE02SC3468
		TRANSISTOR 2SC3468(D)-AE or	QQSD02SC3468
		TRANSISTOR KTC3207	NQS20KTC3207
RESISTORS			

Ref. No.	Mark	Description	Part No.
R501		METAL OXIDE FILM RES. 1W J 15k Ω or	RN01153ZU001
		METAL OXIDE FILM RES. 1W J 15k Ω	RN01153DP003
R502		METAL OXIDE FILM RES. 1W J 15k Ω or	RN01153ZU001
		METAL OXIDE FILM RES. 1W J 15k Ω	RN01153DP003
R503		METAL OXIDE FILM RES. 1W J 15k Ω or	RN01153ZU001
		METAL OXIDE FILM RES. 1W J 15k Ω	RN01153DP003
R504		CARBON RES. 1/4W J 1.5k Ω	RCX4JATZ0152
R505		CARBON RES. 1/4W J 1.5k Ω	RCX4JATZ0152
R506		CARBON RES. 1/4W J 1.5k Ω	RCX4JATZ0152
R509		CARBON RES. 1/4W J 1.5k Ω	RCX4JATZ0152
R511		CHIP RES.(1608) 1/10W J 33 Ω	RRXAJB5Z0330
R512		CHIP RES.(1608) 1/10W J 33 Ω	RRXAJB5Z0330
R513		CHIP RES.(1608) 1/10W J 33 Ω	RRXAJB5Z0330
R514		CARBON RES. 1/4W J 5.6k Ω	RCX4JATZ0562
R515		CARBON RES. 1/4W J 5.6k Ω	RCX4JATZ0562
R516		CARBON RES. 1/4W J 5.6k Ω	RCX4JATZ0562
R517		CARBON RES. 1/4W J 560 Ω or	RCX4JATZ0561
		CARBON RES. 1/6W J 560 Ω	RCX6JATZ0561
R518		CARBON RES. 1/4W J 560 Ω or	RCX4JATZ0561
		CARBON RES. 1/6W J 560 Ω	RCX6JATZ0561
R519		CARBON RES. 1/4W J 560 Ω or	RCX4JATZ0561
		CARBON RES. 1/6W J 560 Ω	RCX6JATZ0561
R521		CHIP RES. 1/10W J 0 Ω	RRXAJB5Z0000
R522		CHIP RES. 1/10W J 0 Ω	RRXAJB5Z0000
R523		CHIP RES. 1/10W J 0 Ω	RRXAJB5Z0000
R537		CARBON RES. 1/4W J 1.5k Ω	RCX4JATZ0152
R538		CARBON RES. 1/4W J 1.5k Ω	RCX4JATZ0152
MISCELLANEOUS			
BC501		BEAD INDUCTORS FBR07HA121TB-00	LLBF00ZTU021
CLN501	A	PARALLEL WIRE L=250 3P	WX1L1000-102
CLN501	B	PARALLEL WIRE 3P	WX1L1114-101
CN501		PIN CONNECTOR 005P-5100	JTEA001TG001
JK501	▲	CRT SOCKET ISMS02S	JSCC220PK003

C6413TD/C6419TD

L6303/6403CD